

1. DEEP GROOVE BALL BEARINGS

INTRODUCTION C 006

TECHNICAL DATA

Radial and Axial Internal Clearances and Contact Angles for Single-Row Deep Groove Ball Bearings C 012

Features and Operating Temperature Range of Ball Bearing Seal Material C 016

Free Space and Grease Filling Amount for Deep Groove Ball Bearings C 018

BEARING TABLES

Single-Row Deep Groove Ball Bearings

Open, Shielded, and Sealed Types

Bore Diameter 10 – 240 mm C 020

Open Type

Bore Diameter 260 – 800 mm C 040

Creep-Free Bearings™

Bore Diameter 10 – 100 mm C 046

Maximum Ball Bearings

Bore Diameter 25 – 110 mm C 048

Magneto Bearings

Bore Diameter 4 – 20 mm C 050



DESIGN, TYPES, AND FEATURES

SINGLE-ROW DEEP GROOVE BALL BEARINGS

Single-row deep groove ball bearings are classified into the types shown below.

The proper amount of good quality grease is packed in shielded and sealed ball bearings. A comparison of the features of each type is shown in Table 1.

Table 1 Features of Sealed Ball Bearings

Type	Shielded (ZZ Type)	Rubber Non-Contact Seal (VV Type)	Rubber Contact Seal (DDU Type)
Torque	Low	Low	Higher than ZZ and VV types due to contact seal
Speed capability	Good	Good	Limited by contact seals
Grease-sealing effectiveness	Good	Better than ZZ type	Slightly better than VV type
Dust resistance	Good	Better than ZZ type (usable in moderately dusty environments)	Best (usable even in very dusty environments)
Water resistance	Not suitable	Not suitable	Good (usable even if fluid is splashed on bearing)
Operating temperature ⁽¹⁾	-10 to +110 °C	-10 to +110 °C	-10 to +100 °C

Note ⁽¹⁾ The above temperature range applies to standard bearings. By using cold- or heat-resistant grease or changing the type of rubber, the operating temperature range can be extended. Please contact NSK for such applications.

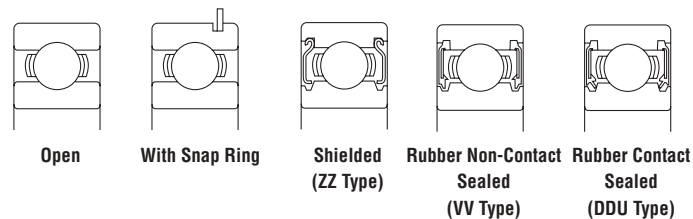

Pressed cages are usually used for deep groove ball bearings. For large bearings, machined brass cages are used (refer to Table 2).
Machined cages are also used for high-speed applications.

Table 2 Standard Cages for Deep Groove Ball Bearings

Series	Pressed Steel Cages	Machined Brass Cages
68	6800 – 6838	6840 – 68/800
69	6900 – 6936	6938 – 69/800
160	16001 – 16026	16028 – 16064
60	6000 – 6040	6044 – 60/670
62	6200 – 6240	6244 – 6272
63	6300 – 6332	6334 – 6356

Formulation of Bearing Designations

Single-row deep groove ball bearings

Example:

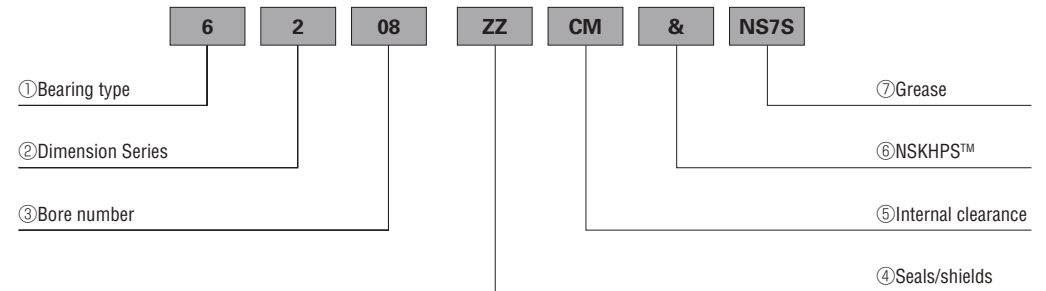

- ① Bearing type: 6 : Single-row deep groove ball bearings
- ② Dimension Series: 2 : 02 Series, 3 : 03 Series, 9 : 19 Series, 0 : 10 Series
- ③ Bore number: Less than 03, Bearing bore 00 : 10mm, 01 : 12mm, 02 : 15mm, 03 : 17mm
Over 04, Bearing bore bore number X 5 (mm)
- ④ Seals/shields: ZZ : Shield on both sides, DDU: Rubber contact seal on both sides, VV: Rubber non-contact seal on both sides, Z: Shield on one side, DU: Rubber contact seal on one side V:Rubber non-contact seal on one side
- ⑤ Internal clearance: Omitted : CN clearance*¹, C3 : Clearance greater than CN, C4 : Clearance greater than C3, CM : For electric motors*¹
- ⑥ NSKHPS™ designation: & : NSKHPS™ Bearings
- ⑦ Grease designation*²: NS7 : NS HI-LUBE

* 1 CM clearance may be used instead of CN clearance (the reverse is not possible).

* 2 The grease designation is required when seals/shields are used on both sides.

NSKHPS™ Deep Groove Ball Bearings

Features Compared with conventional bearings:

- Improved reliability
Bearing life is 15% longer than conventional bearings thanks to optimization of the bearing's internal design and improvement of processing technology. As a result, NSKHPS™ bearings contribute to reducing maintenance costs and facilitate the downscaling of related equipment.
- New product lineup
The standard dimensions are identical to standard size bearings. NSK has expanded the lineup of NSKHPS™ bearings by focusing on a wide range of sizes offering a high degree of versatility for various general-purpose applications.

DEEP GROOVE BALL BEARINGS

Creep-Free Bearings™

Creep-Free bearings, which come with two O-rings mounted in the outer ring, help to prevent creep by restricting the amount of clearance between the outer ring and housing.

No special machining is required; therefore bearings can be used with the same housing as standard bearings.

In creep limit load tests, the more housing clearance is reduced, the greater the improvements in creep prevention due to the tension of the O-ring mounted in the outer ring.

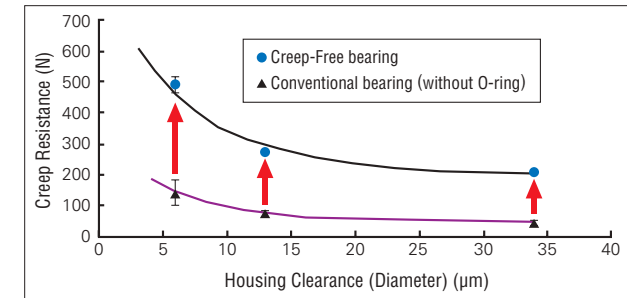
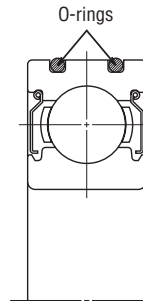

Fig. 1 Structure of Creep-Free Bearings

Fig. 2 Creep Limit Load Test (Example Bearing 6204)

Features

Prevents creep

O-rings help prevent creep.

Easy to assemble

Assembly is easy since bearings can be fitted with a loose tolerance.

Reusable housing

Very little abrasion occurs on the bore surface of the housing, making reuse possible.

No special machining of the housing required

Bearings can be easily replaced since boundary dimensions are identical to standard bearings. No reworking of the housing is required.

Application Examples

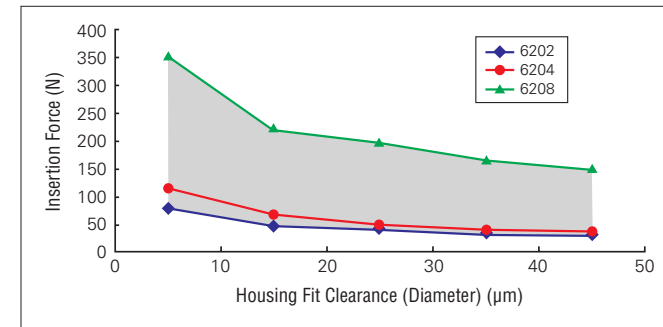
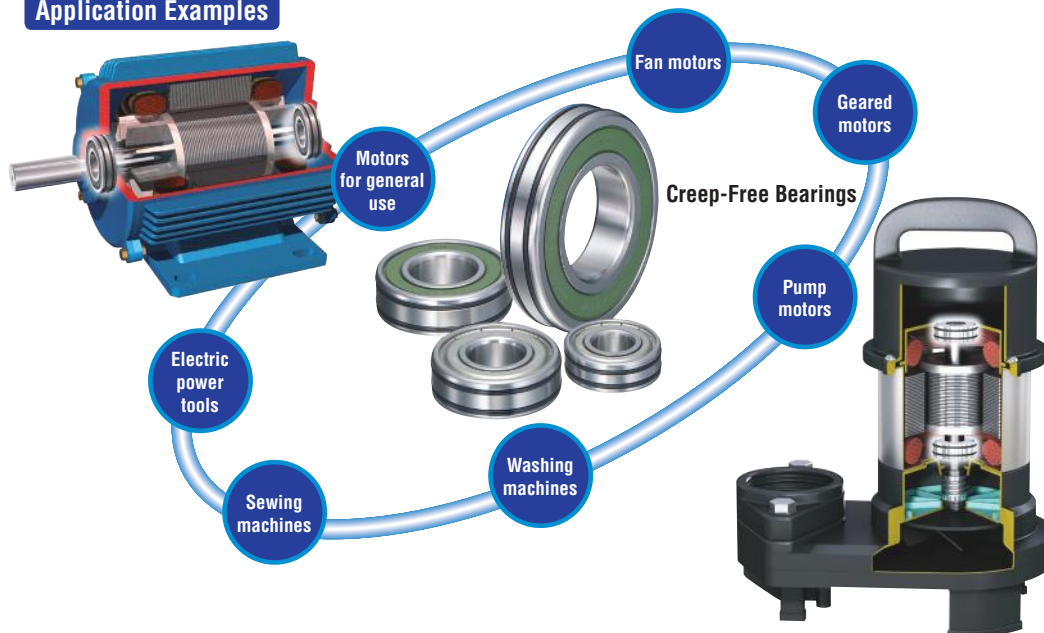

Fig. 3 Fit and Insertion Force

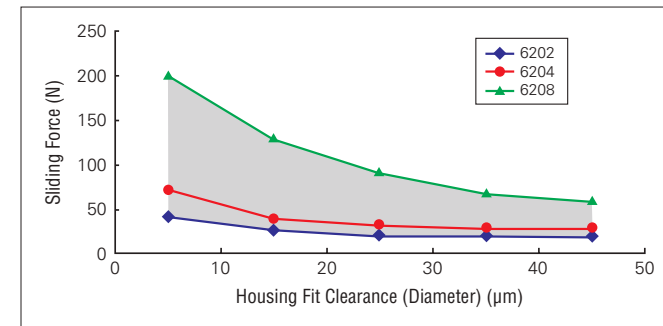

Fig. 4 Fit and Sliding Force



Note on Mounting Creep-Free Bearings

- When oil or grease is applied to the outer diameter of the bearing, use a mineral oil or a synthetic hydrocarbon oil (NSK's EA2, etc.).
- Nitrile rubber is used as the standard specification O-ring material (operating temperature range: -30 to 120 °C). Please contact NSK for use under special environments such as high temperatures.

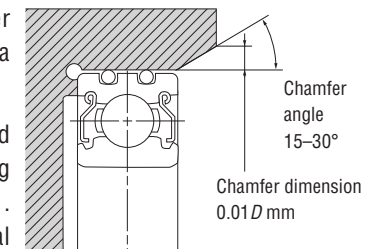
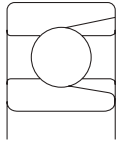

Fig. 5 Housing Shape and Dimension

Note that "free" in the product name "Creep-Free" bearings should not be understood as meaning that creep is nonexistent.

DEEP GROOVE BALL BEARINGS**MAXIMUM BALL BEARINGS**

Maximum ball bearings contain a larger number of balls than normal deep groove ball bearings because of filling slots in the inner and outer rings. Because of their filling slots, they are not suitable for applications with high axial loads.

BL2 and BL3 types of bearings have boundary dimensions equal to those of Series 62 and 63 deep groove ball bearings respectively. Besides the open type, ZZ type shielded bearings are also available.

When using these bearings, it is important for the filling slot in the outer ring to be outside of the loaded zone as much as possible.

The cages are made of pressed steel.

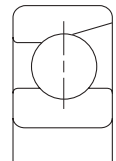
**MAGNETO BEARINGS**

The groove in the inner ring is slightly shallower than that of deep groove ball bearings and one side of the outer ring is relieved. Consequently, the outer ring is separable, which is convenient for mounting.

Pressed cages are standard, but for high-speed applications, machined synthetic resin cages are used.

PRECAUTIONS FOR USE OF DEEP GROOVE BALL BEARINGS

If the bearing load is too small during operation, slippage may occur between the balls and raceways, which may result in smearing. The higher the weight of the balls and cage, the more likely this will occur, especially for large bearings. If very small bearing loads are expected, please contact NSK for selection of an appropriate bearing.

TOLERANCES AND RUNNING ACCURACY

SINGLE-ROW DEEP GROOVE BALL BEARINGS	Table 7.2 (Pages A128 to A131)
NSKHPS DEEP GROOVE BALL BEARINGS	
Tolerance for Dimensions : ISO Normal	
Running Accuracy : ISO Normal	
MAXIMUM BALL BEARINGS	Table 7.2 (Pages A128 to A131)
MAGNETO BEARINGS	Table 7.5 (Pages A138 and A139)

RECOMMENDED FITS

SINGLE-ROW DEEP GROOVE BALL BEARINGS	Table 8.3 (Page A164)
	Table 8.5 (Page A165)
MAXIMUM BALL BEARINGS	Table 8.3 (Page A164)
	Table 8.5 (Page A165)
MAGNETO BEARINGS	Table 8.3 (Page A164)
	Table 8.5 (Page A165)

INTERNAL CLEARANCES

SINGLE-ROW DEEP GROOVE BALL BEARINGS	Table 8.10 (Page A169)
NSKHPS DEEP GROOVE BALL BEARINGS	
INTERNAL CLEARANCE SYMBOL : CN, C3, C4, CM	
MAXIMUM BALL BEARINGS	Table 8.10 (Page A169)
MAGNETO BEARINGS	Table 8.12 (Page A169)

LIMITING SPEEDS (GREASE/OIL)

The limiting speeds for grease and oil lubrication listed in the bearing tables should be adjusted depending on bearing load. Furthermore, higher speeds are attainable by changing the lubrication method, cage design, etc. Refer to Page A098 for detailed information.

DEEP GROOVE BALL BEARINGS

TECHNICAL DATA

Radial and Axial Internal Clearances and Contact Angles for Single-Row Deep Groove Ball Bearings

(1) Radial and Axial Internal Clearances

The internal clearance in single-row bearings is specified as the radial internal clearance. The bearing internal clearance is the amount of relative displacement possible between the bearing rings when one ring is fixed and the other ring does not bear a load. The amount of movement along the bearing radius is called the radial clearance, and the amount along the axis is called the axial clearance.

The geometric relation between radial and axial clearance is shown in Fig. 1.

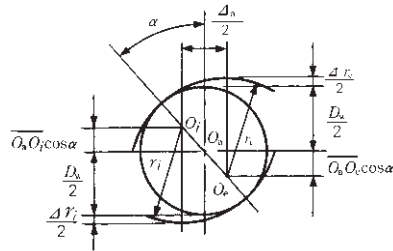

Fig. 1 Relationship Between Δ_r and Δ_a

Symbols used in Fig. 1

- O_a : Ball center
- O_e : Center of groove curvature, outer ring
- O_i : Center of groove curvature, inner ring
- D_w : Ball diameter (mm)
- r_e : Radius of outer ring groove (mm)
- r_i : Radius of inner ring groove (mm)
- α : Contact angle ($^\circ$)
- Δ_r : Radial clearance (mm)
- Δ_a : Axial clearance (mm)

It is apparent from Fig. 1 that $\Delta_r = \Delta r_e + \Delta r_i$.

Various equations for clearance, contact angle, etc. can be derived from geometric relationships:

$$\Delta_r = 2(1 - \cos \alpha)(r_e + r_i - D_w) \dots\dots\dots (1)$$

$$\Delta_a = 2 \sin \alpha (r_e + r_i - D_w) \dots\dots\dots (2)$$

$$\frac{\Delta_a}{\Delta_r} = \cot \frac{\alpha}{2} \dots\dots\dots (3)$$

$$\Delta_a \doteq 2 (r_e + r_i - D_w)^{1/2} \Delta_r^{1/2} \dots\dots\dots (4)$$

$$\alpha = \cos^{-1} \left(\frac{r_e + r_i - D_w - \frac{\Delta_r}{2}}{r_e + r_i - D_w} \right) \dots\dots\dots (5)$$

$$= \sin^{-1} \left(\frac{\Delta_a/2}{r_e + r_i - D_w} \right) \dots\dots\dots (6)$$

Because $(r_e + r_i - D_w)$ is a constant, fixed relationships between Δ_r , Δ_a , and α exist for all the various bearing types.

As previously mentioned, the clearances for deep groove ball bearings are given as radial clearances, but there are specific applications where an axial clearance is desirable as well. The relationship between deep groove ball bearing radial clearance Δ_r and axial clearance Δ_a is given in Equation (4). To simplify,

$$\Delta_a \doteq K \Delta_r^{1/2} \dots\dots\dots (7)$$

where K : Constant depending on bearing design
 $K = 2 (r_e + r_i - D_w)^{1/2}$

Fig. 2 shows one example. The various values for K are presented by bearing size in Table 1 below.

Example

Assume bearing 6312 has a radial clearance of 0.017 mm. From Table 1, $K=2.09$. Therefore, the axial clearance Δ_a is:
 $\Delta_a = 2.09 \times \sqrt{0.017} = 2.09 \times 0.13 = 0.27$ (mm)

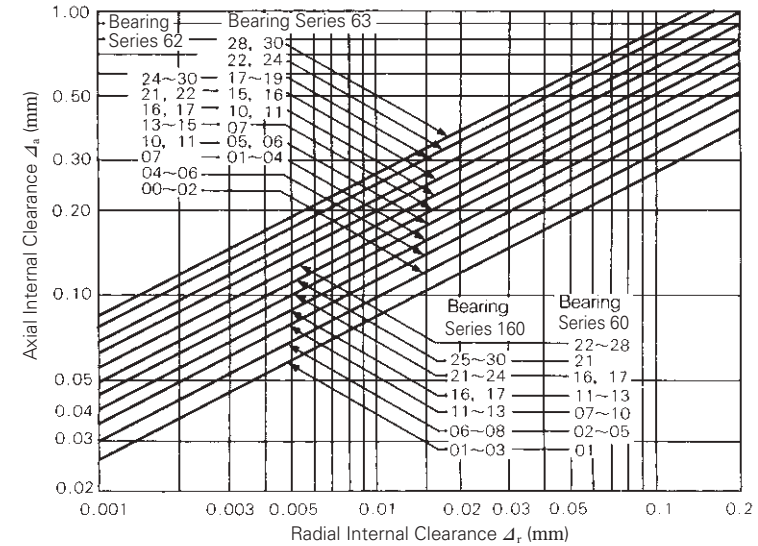

Fig. 2 Radial Clearance Δ_r and Axial Clearance Δ_a of Deep Groove Ball Bearings

Table 1 Constant Values of K for Radial and Axial Clearance Conversion

Bearing Bore No.	K			
	Series 160	Series 60	Series 62	Series 63
00	—	—	0.93	1.14
01	0.80	0.80	0.93	1.06
02	0.80	0.93	0.93	1.06
03	0.80	0.93	0.99	1.11
04	0.90	0.96	1.06	1.07
05	0.90	0.96	1.06	1.20
06	0.96	1.01	1.07	1.19
07	0.96	1.06	1.25	1.37
08	0.96	1.06	1.29	1.45
09	1.01	1.11	1.29	1.57
10	1.01	1.11	1.33	1.64
11	1.06	1.20	1.40	1.70
12	1.06	1.20	1.50	2.09
13	1.06	1.20	1.54	1.82
14	1.16	1.29	1.57	1.88
15	1.16	1.29	1.57	1.95
16	1.20	1.37	1.64	2.01
17	1.20	1.37	1.70	2.06
18	1.29	1.44	1.76	2.11
19	1.29	1.44	1.82	2.16
20	1.29	1.44	1.88	2.25
21	1.37	1.54	1.95	2.32
22	1.40	1.64	2.01	2.40
24	1.40	1.64	2.06	2.40
26	1.54	1.70	2.11	2.49
28	1.54	1.70	2.11	2.59
30	1.57	1.76	2.11	2.59

(2) Relation Between Radial Clearance and Contact Angle

Single-row deep groove ball bearings are sometimes used as thrust bearings. In such applications, the contact angle should be as large as possible.

The contact angle for ball bearings is determined by the geometric relationship between the radial clearance and radii of the inner and outer grooves. Using Equations (1) to (6), Fig. 3 shows the particular relationship between the radial clearance and contact angle of bearings in Series 62 and 63 bearings. The initial contact angle, α_0 , refers to the initial contact angle when axial load is zero. Application of any load to the bearing will change this contact angle.

If the initial contact angle α_0 exceeds 20°, check whether or not the contact area of the ball and raceway touch the edge of the raceway shoulder (refer to Section 8.1.2).

For applications where an axial load alone is applied, the radial clearance for deep groove ball bearings is normally greater than the normal clearance in order to ensure that the contact angle is relatively large. The initial contact angles for C3 and C4 clearances are given for selected bearing sizes in Table 2 below.

Table 2 Initial Contact Angle α_0 , With C3 and C4 Clearances

Bearing Designation	α_0 with C3	α_0 with C4
6205	12.5° to 18°	16.5° to 22°
6210	11.5° to 16.5°	13.5° to 19.5°
6215	11.5° to 16°	15.5° to 19.5°
6220	10.5° to 14.5°	14° to 17.5°
6305	11° to 16°	14.5° to 19.5°
6310	9.5° to 13.5°	12° to 16°
6315	9.5° to 13.5°	12.5° to 15.5°
6320	9° to 12.5°	12° to 15°

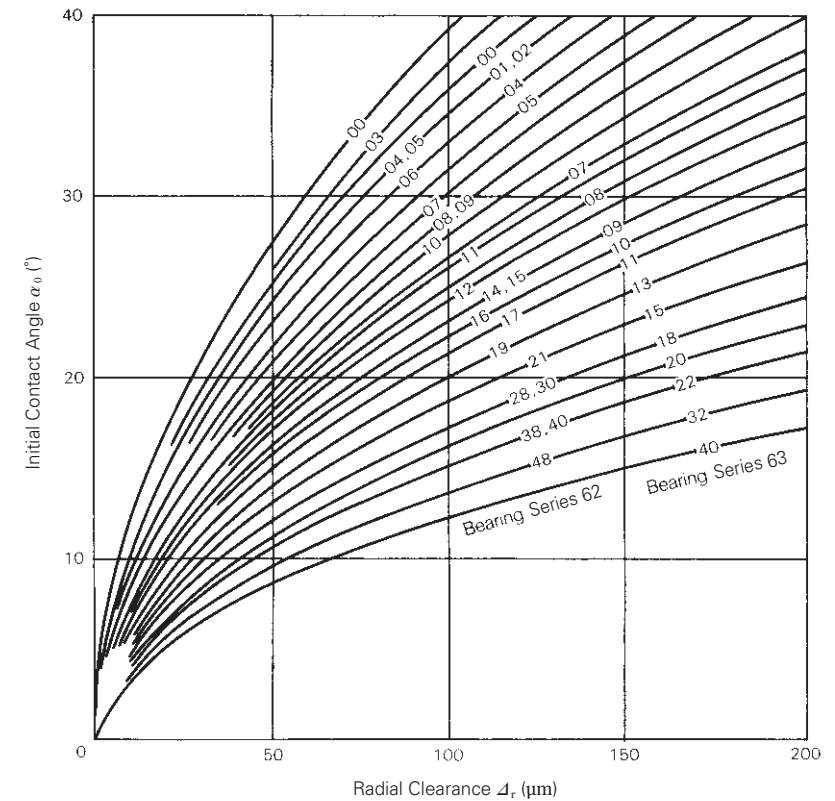

Fig. 3 Radial Clearance and Contact Angle

Features and Operating Temperature Range of Ball Bearing Seal Material

Sealed ball bearings are shown in Figs. 1 and 2. There are two seal types: non-contact seals and contact seals. Nitrile rubber is used for general-purpose applications, while polyacrylic, silicon, and fluorine rubbers are used based on operating temperature requirements. All rubbers have their own unique characteristics and must be selected while considering the application environment and operating conditions.

Table 1 shows principal features of each rubber material and the operating temperature range of the bearing seal. The operating temperature range of Table 1 is a guideline for continuous operation. Thermal aging of rubber is related to temperature and time. Rubber may be used in a much wider range of operating temperatures depending on the operating time and frequency.

Heat generation due to friction on the lip can be ignored in non-contact seals. Thermal factors, which cause aging of the rubber, refer to physical changes due to atmospheric and bearing temperatures. Accordingly, increased hardness or loss of elasticity due to thermal aging exerts only a negligible effect on seal performance. A rubber non-contact seal can thus be used in a greater range of operating temperatures than contact seals.

However, there are some disadvantages. Problems with friction-generated wear at the seal lip, thermal plastic deformation, and hardening may occur, causing the contact pressure between the lip and slide surface to decrease and result in a clearance. This clearance is low and does not degrade sealing performance (it does not cause dust entry or grease leakage). In most cases, this minor plastic deformation or increased hardness presents no practical problems.

However, in external environments with large amounts of dust and water, the bearing seal is used as an auxiliary seal and a main seal should be provided separately. As mentioned, the operating temperature range of rubber material is only a guideline for selection. Since heat resistant rubber is expensive, strive to understand temperature conditions so that an economical selection can be made. Pay attention not only to heat resistance, but also to the distinctive features of each rubber.

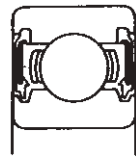

Rubber non-contact seal (VV)

Fig. 1

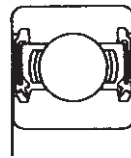

Rubber contact seal (DDU)

Fig. 2

Table 1 Features and Operating Temperature Range of Rubber Materials

Material		Nitrile Rubber	Polyacrylic Rubber	Silicon Rubber	Fluorine Rubber
Key features		<ul style="list-style-type: none"> ○Most popular seal material ○Superior mechanical properties and resistance to oil and wear ○Readily ages under direct sunlight ○Less expensive than other rubbers 	<ul style="list-style-type: none"> ○Superior heat and oil resistances ○Large compression causes permanent deformation ○Inferior cold resistance ○One of the less expensive high-temperature materials ○Swells in contact with ester oil based grease 	<ul style="list-style-type: none"> ○High heat and cold resistances ○Inferior mechanical properties besides resistance to permanent deformation by compression. Note the tear strength ○Swells in contact with low-anilinepoint mineral oil, silicone grease, and silicone oil 	<ul style="list-style-type: none"> ○High heat resistance ○Superior oil and chemical resistances ○Cold resistance similar to nitrile rubber ○Deteriorates in contact with urea grease
	Operating Temperature Range ⁽¹⁾ (°C)	Non-Contact Seal	-50 to +130	-30 to +170	-100 to +250
	Contact Seal	-30 to +110	-15 to +150	-70 to +200	-30 to +200

Note ⁽¹⁾ This operating temperature refers to the temperature of rubber seal materials.

Free Space and Grease Filling Amount for Deep Groove Ball Bearings

Grease lubrication can simplify the bearing's peripheral construction. Thanks to enhanced grease quality, grease lubrication is now employed in place of oil lubrication in many fields. Be sure to select a grease appropriate for operating conditions. Take care with the filling amount, since too much or too little grease greatly affects the temperature rise and torque. The amount of grease needed depends on such factors as housing construction, free space, grease brand, and environment.

As a general guideline, the bearing is first filled with an appropriate amount of grease. Apply grease onto the cage guide surface, then, fill the free space, which excludes the spindle and bearing inside the housing, with the following amount of grease:

When bearing speed is 50% or less of the specified limiting speed, fill 1/2 to 2/3 of the free space.

When bearing speed is 50% or more of the specified limiting speed, fill 1/3 to 1/2 of the free space.

In general, low speeds require more grease while high speeds require less grease. Depending on the particular application, the filling amount may have to be reduced further to reduce the torque and prevent heat generation. When bearing speed is extremely low on the other hand, grease may be packed almost full to prevent dust and water entry. Accordingly, one must know the extent of the housing's free space for the specific bearing to determine the correct filling amount. The volume of free space is shown in Table 1 for an open deep groove ball bearing for reference.

Note that the free space of the open type deep groove ball bearing is the volume obtained by subtracting the volume of the balls and cage from the space formed between inner and outer rings.

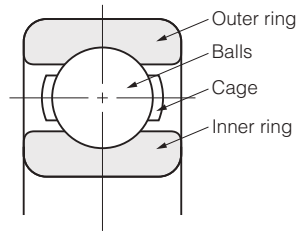

Table 1 Free Space of Open Deep Groove Ball Bearings

Units : cm³

Bearing Bore No.	Bearing Free Space			Bearing Bore No.	Bearing Free Space		
	Bearing Series				Bearing Series		
	60	62	63		60	62	63
00	1.2	1.5	2.9	14	34	61	148
01	1.2	2.1	3.5	15	35	67	180
02	1.6	2.7	4.8	16	47	84	213
03	2.0	3.7	6.4	17	48	104	253
04	4.0	6.0	7.9	18	63	127	297
05	4.6	7.7	12	19	66	155	345
06	6.5	11	19	20	68	184	425
07	9.2	15	25	21	88	216	475
08	11	20	35	22	114	224	555
09	14	23	49	24	122	310	675
10	15	28	64	26	172	355	830
11	22	34	79	28	180	415	1 030
12	23	45	98	30	220	485	1 140
13	24	54	122	32	285	545	1 410

Remark The table above shows the free space of bearings using pressed-steel cages. The free space of a bearing using a high-tension machined-brass cage is about 50 to 60% of the value in this table.

■ SINGLE-ROW DEEP GROOVE BALL BEARINGS

Bore Diameter 10 – 17 mm

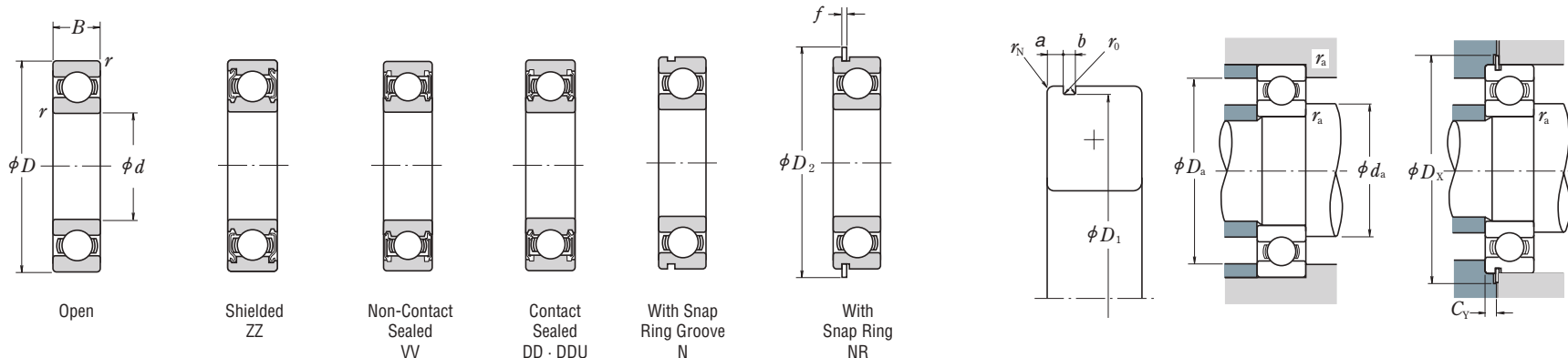

Dynamic Equivalent Load

$$P = XF_r + YF_a$$

$\frac{f_0 F_a}{C_{0r}}$	e	$\frac{F_a}{F_r} \leq e$		$\frac{F_a}{F_r} > e$	
		X	Y	X	Y
0.172	0.19	1	0	0.56	2.30
0.345	0.22	1	0	0.56	1.99
0.689	0.26	1	0	0.56	1.71
1.03	0.28	1	0	0.56	1.55
1.38	0.30	1	0	0.56	1.45
2.07	0.34	1	0	0.56	1.31
3.45	0.38	1	0	0.56	1.15
5.17	0.42	1	0	0.56	1.04
6.89	0.44	1	0	0.56	1.00

Static Equivalent Load

$$\frac{F_a}{F_r} > 0.8, P_0 = 0.6F_r + 0.5F_a$$

$$\frac{F_a}{F_r} \leq 0.8, P_0 = F_r$$

Boundary Dimensions (mm)	Basic Load Ratings (N)		Factor f_0	Limiting Speeds (min ⁻¹)			Bearing Designations			Snap Ring Groove Dimensions (1) (mm)					Snap Ring (1) Dimensions (mm)		Abutment and Fillet Dimensions (mm)					Mass (kg) approx.					
	d	D		B	r min.	C _r	C _{0r}	Grease	Oil	Open	Shielded	Sealed	a max.	b min.	D ₁ max.	r ₀ max.	r _N min.	D ₂ max.	f max.	d _a (2) min.	D _a (2) max.		r _a max.	D _x min.	C _y max.		
10	19	5	0.3	1 720	840	14.8	34 000	24 000	40 000	6800	ZZ	VV	DD	—	—	—	—	—	—	12	12	17	0.3	—	—	0.005	
	22	6	0.3	2 700	1 270	14.0	32 000	22 000	38 000	6900	ZZ	VV	DD	N ⁽³⁾	NR ⁽³⁾	1.05	0.8	20.8	0.2	0.2	12	12.5	20	0.3	25.5	1.5	0.009
	26	8	0.3	4 550	1 970	12.4	30 000	22 000	36 000	6000	ZZ	VV	DDU	N ⁽⁴⁾	NR ⁽⁴⁾	1.35	0.87	24.5	0.2	0.3	12	13	24	0.3	29.4	1.9	0.018
	30	9	0.6	5 350	2 390	13.2	28 000	18 000	34 000	* 6200	ZZ	VV	DDU	—	—	—	—	—	—	—	14	16	26	0.6	—	—	0.032
	30	9	0.6	5 100	2 390	13.2	24 000	18 000	30 000	6200	ZZ	VV	DDU	N	NR	2.06	1.35	28.17	0.4	0.5	14	16	26	0.6	35.5	2.9	0.032
	35	11	0.6	8 500	3 450	11.2	26 000	17 000	30 000	* 6300	ZZ	VV	DDU	—	—	—	—	—	—	—	14	16.5	31	0.6	—	—	0.052
35	11	0.6	8 100	3 450	11.2	22 000	17 000	26 000	6300	ZZ	VV	DDU	N	NR	2.06	1.35	33.17	0.4	0.5	14	16.5	31	0.6	40.5	2.9	0.052	
12	21	5	0.3	1 920	1 040	15.3	32 000	20 000	38 000	6801	ZZ	VV	DD	—	—	—	—	—	—	14	14	19	0.3	—	—	0.006	
	24	6	0.3	2 890	1 460	14.5	30 000	20 000	36 000	6901	ZZ	VV	DD	N ⁽³⁾	NR ⁽³⁾	1.05	0.8	22.8	0.2	0.2	14	14.5	22	0.3	27.5	1.5	0.010
	28	7	0.3	5 100	2 370	13.0	28 000	—	32 000	16001	—	—	—	—	—	—	—	—	—	14	—	26	0.3	—	—	0.019	
	28	8	0.3	5 350	2 370	13.0	32 000	18 000	38 000	* 6001	ZZ	VV	DDU	—	—	—	—	—	—	14	15.5	26	0.3	—	—	0.022	
	28	8	0.3	5 100	2 370	13.0	28 000	18 000	32 000	6001	ZZ	VV	DDU	N ⁽⁴⁾	NR ⁽⁴⁾	1.35	0.87	26.5	0.2	0.3	14	15.5	26	0.3	31.4	1.9	0.022
	32	10	0.6	7 150	3 050	12.3	26 000	17 000	32 000	* 6201	ZZ	VV	DDU	—	—	—	—	—	—	16	17	28	0.6	—	—	0.037	
15	24	5	0.3	2 070	1 260	15.8	22 000	17 000	28 000	6201	ZZ	VV	DDU	N	NR	2.06	1.35	30.15	0.4	0.5	16	17	28	0.6	37.5	2.9	0.037
	28	7	0.3	4 350	2 260	14.3	24 000	16 000	28 000	* 6301	ZZ	VV	DDU	—	—	—	—	—	—	17	18	32	1	—	—	0.060	
	32	8	0.3	5 600	2 830	13.9	20 000	16 000	24 000	6301	ZZ	VV	DDU	N	NR	2.06	1.35	34.77	0.4	0.5	17	18	32	1	42	2.9	0.060
	32	9	0.3	5 850	2 830	13.9	28 000	17 000	34 000	6802	ZZ	VV	DD	—	—	—	—	—	—	17	17	22	0.3	—	—	0.007	
	32	9	0.3	4 350	2 260	14.3	26 000	17 000	30 000	6902	ZZ	VV	DD	N ⁽³⁾	NR ⁽³⁾	1.30	0.95	26.7	0.25	0.3	17	17	26	0.3	31.5	1.8	0.015
	35	11	0.6	8 000	3 750	13.2	24 000	—	28 000	16002	—	—	—	—	—	—	—	—	—	17	—	30	0.3	—	—	0.027	
17	32	9	0.3	5 850	2 830	13.9	26 000	15 000	32 000	* 6002	ZZ	VV	DDU	—	—	—	—	—	—	17	19	30	0.3	—	—	0.031	
	32	9	0.3	5 600	2 830	13.9	24 000	15 000	28 000	6002	ZZ	VV	DDU	N	NR	2.06	1.35	30.15	0.4	0.3	17	19	30	0.3	37.5	2.9	0.031
	35	11	0.6	8 000	3 750	13.2	22 000	14 000	28 000	* 6202	ZZ	VV	DDU	—	—	—	—	—	—	19	20.5	31	0.6	—	—	0.045	
	35	11	0.6	7 650	3 750	13.2	20 000	14 000	24 000	6202	ZZ	VV	DDU	N	NR	2.06	1.35	33.17	0.4	0.5	19	20.5	31	0.6	40.5	2.9	0.045
	42	13	1	12 000	5 450	12.3	19 000	13 000	24 000	* 6302	ZZ	VV	DDU	—	—	—	—	—	—	20	22.5	37	1	—	—	0.083	
	42	13	1	11 400	5 450	12.3	17 000	13 000	20 000	6302	ZZ	VV	DDU	N	NR	2.06	1.35	39.75	0.4	0.5	20	22.5	37	1	47	2.9	0.083
20	26	5	0.3	2 630	1 570	15.7	26 000	15 000	30 000	6803	ZZ	VV	DD	—	—	—	—	—	—	19	19	24	0.3	—	—	0.007	
	30	7	0.3	4 600	2 550	14.7	24 000	15 000	28 000	6903	ZZ	VV	DDU	N ⁽³⁾	NR ⁽³⁾	1.30	0.95	28.7	0.25	0.3	19	19.5	28	0.3	33.5	1.8	0.017
	35	8	0.3	6 000	3 250	14.4	22 000	—	26 000	16003	—	—	—	—	—	—	—	—	19	—	33	0.3	—	—	0.033		
	35	10	0.3	6 300	3 250	14.4	24 000	13 000	28 000	* 6003	ZZ	VV	DDU	—	—	—	—	—	—	19	21.5	33	0.3	—	—	0.041	
	35	10	0.3	6 000	3 250	14.4	22 000	13 000	26 000	6003	ZZ	VV	DDU	N	NR	2.06	1.35	33.17	0.4	0.3	19	21.5	33	0.3	40.5	2.9	0.041
	40	12	0.6	10 100	4 800	13.2	20 000	12 000	24 000	* 6203	ZZ	VV	DDU	—	—	—	—	—	—	21	23.5	36	0.6	—	—	0.067	
25	40	12	0.6	9 550	4 800	13.2	17 000	12 000	20 000	6203	ZZ	VV	DDU	N	NR	2.06	1.35	38.1	0.4	0.5	21	23.5	36	0.6	45.5	2.9	0.067
	47	14	1	14 300	6 650	12.4	17 000	11 000	20 000	* 6303	ZZ	VV	DDU	—	—	—	—	—	—	22	25.5	42	1	—	—	0.113	
	47	14	1	13 600	6 650	12.4	15 000	11 000	18 000	6303	ZZ	VV	DDU	N	NR	2.46	1.35	44.6	0.4	0.5	22	25.5	42	1	53.5	3.3	0.113

- Notes (1) For tolerances of snap ring grooves and snap ring dimensions, refer to Pages A116 to A119.
 (2) When heavy axial loads are applied, d_a and D_a can be adjusted up to the shoulder diameter of the races. Please consult NSK for details.
 (3) Ring types N and NR are applicable only to open bearings. Please consult NSK about the snap ring groove dimensions of sealed or shielded bearings.
 (4) Snap ring groove dimensions and snap ring dimensions do not conform to ISO15.

- Remarks 1. Diameter Series 7 (extra-thin wall) bearings are also available; please contact NSK for details.
 2. When using bearings with rotating outer rings, contact NSK if they are sealed, shielded, or have snap rings.
 3. Bearings denoted by an asterisk (*) are NSKHPS™ deep groove ball bearings.

■ SINGLE-ROW DEEP GROOVE BALL BEARINGS

Bore Diameter 20 – 30 mm

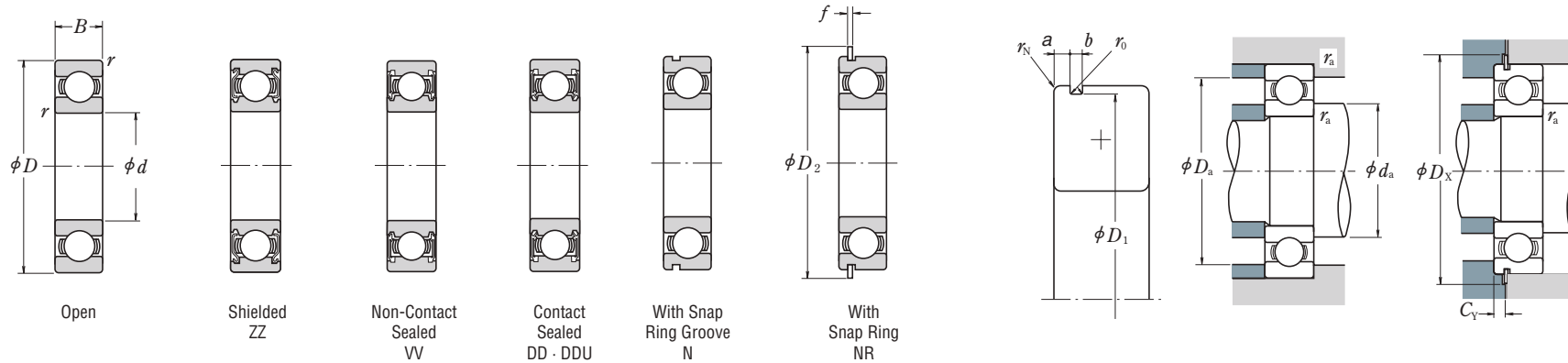

Dynamic Equivalent Load

$$P = XF_r + YF_a$$

$\frac{f_0 F_a}{C_{0r}}$	e	$\frac{F_a}{F_r} \leq e$		$\frac{F_a}{F_r} > e$	
		X	Y	X	Y
0.172	0.19	1	0	0.56	2.30
0.345	0.22	1	0	0.56	1.99
0.689	0.26	1	0	0.56	1.71
1.03	0.28	1	0	0.56	1.55
1.38	0.30	1	0	0.56	1.45
2.07	0.34	1	0	0.56	1.31
3.45	0.38	1	0	0.56	1.15
5.17	0.42	1	0	0.56	1.04
6.89	0.44	1	0	0.56	1.00

Static Equivalent Load

$$\frac{F_a}{F_r} > 0.8, P_0 = 0.6F_r + 0.5F_a$$

$$\frac{F_a}{F_r} \leq 0.8, P_0 = F_r$$

Boundary Dimensions (mm)	Basic Load Ratings (N)		Factor	Limiting Speeds (min ⁻¹)			Bearing Designations			Snap Ring Groove Dimensions (1)					Snap Ring (1) Dimensions (mm)		Abutment and Fillet Dimensions (mm)					Mass (kg)					
										(mm)					D ₂		d _a (2)										
										d	D	B	r _{min.}	C _r	C _{0r}	f ₀	Grease	Oil	Open	Shielded	Sealed		With Snap Ring Groove	With Snap Ring	a	b	D ₁
20	32	7	0.3	4 000	2 470	15.5	22 000	13 000	26 000	6804 ZZ VV DD	N	NR	1.30	0.95	30.7	0.25	0.3	34.8	0.85	22	22	30	0.3	35.5	1.8	0.017	

- Notes**
- (1) For tolerances of snap ring grooves and snap ring dimensions, refer to Pages A116 to A119.
 - (2) When heavy axial loads are applied, d_a and D_a can be adjusted up to the shoulder diameter of the races. Please consult NSK for details.
 - (3) Ring types N and NR are applicable only to open bearings. Please consult NSK about the snap ring groove dimensions of sealed or shielded bearings.

- Remarks**
- Diameter Series 7 (extra-thin wall) bearings are also available; please contact NSK for details.
 - When using bearings with rotating outer rings, contact NSK if they are sealed, shielded, or have snap rings.
 - Bearings denoted by an asterisk (*) are NSKHPS™ deep groove ball bearings.

■ SINGLE-ROW DEEP GROOVE BALL BEARINGS

Bore Diameter 32 – 45 mm

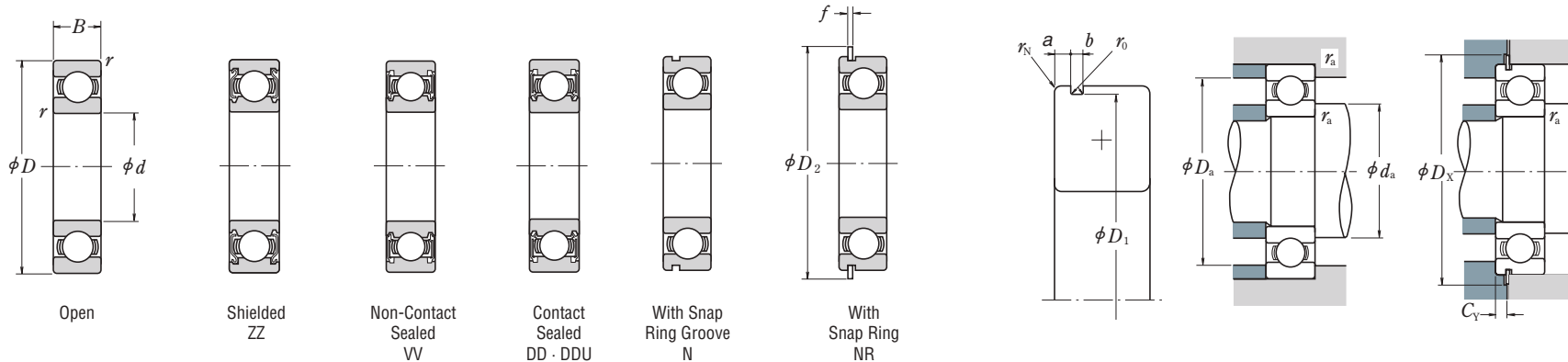

Dynamic Equivalent Load

$$P = XF_r + YF_a$$

$\frac{f_0 F_a}{C_{0r}}$	e	$\frac{F_a}{F_r} \leq e$		$\frac{F_a}{F_r} > e$	
		X	Y	X	Y
0.172	0.19	1	0	0.56	2.30
0.345	0.22	1	0	0.56	1.99
0.689	0.26	1	0	0.56	1.71
1.03	0.28	1	0	0.56	1.55
1.38	0.30	1	0	0.56	1.45
2.07	0.34	1	0	0.56	1.31
3.45	0.38	1	0	0.56	1.15
5.17	0.42	1	0	0.56	1.04
6.89	0.44	1	0	0.56	1.00

Static Equivalent Load

$$\frac{F_a}{F_r} > 0.8, P_0 = 0.6F_r + 0.5F_a$$

$$\frac{F_a}{F_r} \leq 0.8, P_0 = F_r$$

Boundary Dimensions (mm)				Basic Load Ratings (N)		Factor	Limiting Speeds (min ⁻¹)			Bearing Designations			Snap Ring Groove Dimensions (1) (mm)					Snap Ring (1) Dimensions (mm)		Abutment and Fillet Dimensions (mm)					Mass (kg)				
d	D	B	r min.	C_r	C_{0r}	f_0	Grease		Oil	Open	Shielded	Sealed	With Snap Ring Groove	With Snap Ring Groove	a max.	b min.	D_1 max.	r_0 max.	r_N min.	D_2 max.	f max.	d_a (2) min.	d_a (2) max.	D_a (2) max.	r_a max.	D_x min.	C_y max.	approx.	
32	58	13	1	15 100	9 150	14.5	12 000	7 500	14 000	60/32	ZZ	VV	DDU	N	NR	2.08	1.35	55.6	0.4	0.5	63.7	1.12	37	38.5	53	1	64.5	2.9	0.122
	65	17	1	20 700	11 600	13.6	10 000	7 100	12 000	62/32	ZZ	VV	DDU	N	NR	3.28	1.9	62.6	0.6	0.5	70.7	1.7	37	40	60	1	71.5	4.6	0.225
	75	20	1.1	29 900	17 000	13.2	9 000	6 300	11 000	63/32	ZZ	VV	DDU	N	NR	3.28	1.9	71.83	0.6	0.5	81.6	1.7	38.5	44.5	68.5	1	83	4.6	0.389
35	47	7	0.3	4 900	4 100	16.7	14 000	7 500	16 000	6807	ZZ	VV	DD	N	NR	1.30	0.95	45.7	0.25	0.3	49.8	0.85	37	37	45	0.3	50.5	1.8	0.027
	55	10	0.6	10 600	7 250	15.5	12 000	7 500	15 000	6907	ZZ	VV	DDU	N	NR	1.70	0.95	53.7	0.25	0.5	57.8	0.85	39	39	51	0.6	58.5	2.3	0.075
	62	9	0.3	11 700	8 200	15.6	11 000	—	13 000	16007	—	—	—	—	—	—	—	—	—	—	—	—	—	60	0.3	—	—	—	0.107
35	62	14	1	16 800	10 300	14.8	13 000	6 700	15 000	* 6007	ZZ	VV	DDU	—	—	—	—	—	—	—	—	—	40	41.5	57	1	—	—	0.151
	62	14	1	16 000	10 300	14.8	11 000	6 700	13 000	6007	ZZ	VV	DDU	N	NR	2.08	1.9	59.61	0.6	0.5	67.7	1.7	40	41.5	57	1	68.5	3.4	0.151
	72	17	1.1	27 000	15 300	13.8	11 000	6 300	13 000	* 6207	ZZ	VV	DDU	—	—	—	—	—	—	—	—	—	41.5	44.5	65.5	1	—	—	0.284
35	72	17	1.1	25 700	15 300	13.8	9 500	6 300	11 000	6207	ZZ	VV	DDU	N	NR	3.28	1.9	68.81	0.6	0.5	78.6	1.7	41.5	44.5	65.5	1	80	4.6	0.284
	80	21	1.5	35 000	19 200	13.2	10 000	6 000	12 000	* 6307	ZZ	VV	DDU	—	—	—	—	—	—	—	—	—	43	47	72	1.5	—	—	0.464
	80	21	1.5	33 500	19 200	13.2	8 500	6 000	10 000	6307	ZZ	VV	DDU	N	NR	3.28	1.9	76.81	0.6	0.5	86.6	1.7	43	47	72	1.5	88	4.6	0.464
40	52	7	0.3	6 350	5 550	17.0	12 000	6 700	14 000	6808	ZZ	VV	DD	N	NR	1.30	0.95	50.7	0.25	0.3	54.8	0.85	42	42	50	0.3	55.5	1.8	0.031
	62	12	0.6	13 700	10 000	15.7	11 000	6 300	13 000	6908	ZZ	VV	DDU	N	NR	1.70	0.95	60.7	0.25	0.5	64.8	0.85	44	46	58	0.6	65.5	2.3	0.112
	68	9	0.3	12 600	9 650	16.0	10 000	—	12 000	16008	—	—	—	—	—	—	—	—	—	—	—	—	—	66	0.3	—	—	—	0.13
40	68	15	1	17 600	11 500	15.3	12 000	6 000	14 000	* 6008	ZZ	VV	DDU	—	—	—	—	—	—	—	—	—	45	47.5	63	1	—	—	0.19
	68	15	1	16 800	11 500	15.3	10 000	6 000	12 000	6008	ZZ	VV	DDU	N	NR	2.49	1.9	64.82	0.6	0.5	74.6	1.7	45	47.5	63	1	76	3.8	0.19
	80	18	1.1	30 500	17 900	14.0	9 500	5 600	12 000	* 6208	ZZ	VV	DDU	—	—	—	—	—	—	—	—	—	46.5	50.5	73.5	1	—	—	0.366
40	80	18	1.1	29 100	17 900	14.0	8 500	5 600	10 000	6208	ZZ	VV	DDU	N	NR	3.28	1.9	76.81	0.6	0.5	86.6	1.7	46.5	50.5	73.5	1	88	4.6	0.366
	90	23	1.5	43 000	24 000	13.2	9 000	5 300	11 000	* 6308	ZZ	VV	DDU	—	—	—	—	—	—	—	—	—	48	53	82	1.5	—	—	0.636
	90	23	1.5	40 500	24 000	13.2	7 500	5 300	9 000	6308	ZZ	VV	DDU	N	NR	3.28	2.7	86.79	0.6	0.5	96.5	2.46	48	53	82	1.5	98	5.4	0.636
45	58	7	0.3	6 600	6 150	17.2	11 000	6 000	13 000	6809	ZZ	VV	DD	N	NR	1.30	0.95	56.7	0.25	0.3	60.8	0.85	47	47.5	56	0.3	61.5	1.8	0.038
	68	12	0.6	14 100	10 900	15.9	9 500	5 600	12 000	6909	ZZ	VV	DDU	N	NR	1.70	0.95	66.7	0.25	0.3(3)	70.8	0.85	49	50	64	0.6	72	2.3	0.126
	75	10	0.6	14 900	11 400	15.9	9 000	—	11 000	16009	—	—	—	—	—	—	—	—	—	—	—	—	—	71	0.6	—	—	—	0.167
45	75	16	1	22 000	15 200	15.3	10 000	5 300	12 000	* 6009	ZZ	VV	DDU	—	—	—	—	—	—	—	—	—	50	53.5	70	1	—	—	0.241
	75	16	1	20 900	15 200	15.3	9 000	5 300	11 000	6009	ZZ	VV	DDU	N	NR	2.49	1.9	71.83	0.6	0.5	81.6	1.7	50	53.5	70	1	83	3.8	0.241
	85	19	1.1	33 000	20 400	14.4	9 000	5 300	11 000	* 6209	ZZ	VV	DDU	—	—	—	—	—	—	—	—	—	51.5	55.5	78.5	1	—	—	0.42
45	85	19	1.1	31 500	20 400	14.4	7 500	5 300	9 000	6209	ZZ	VV	DDU	N	NR	3.28	1.9	81.81	0.6	0.5	91.6	1.7	51.5	55.5	78.5	1	93	4.6	0.42
	100	25	1.5	55 500	32 000	13.1	7 500	4 800	9 500	* 6309	ZZ	VV	DDU	—	—	—	—	—	—	—	—	—	53	61.5	92	1.5	—	—	0.829
	100	25	1.5	53 000	32 000	13.1	6 700	4 800	8 000	6309	ZZ	VV	DDU	N	NR	3.28	2.7	96.8	0.6	0.5	106.5	2.46	53	61.5	92	1.5	108	5.4	0.829

- Notes** (1) For tolerances of snap ring grooves and snap ring dimensions, refer to Pages A116 to A119.
 (2) When heavy axial loads are applied, d_a and D_a can be adjusted up to the shoulder diameter of the races. Please consult NSK for details.
 (3) Does not conform to ISO15.

- Remarks** 1. Diameter Series 7 (extra-thin wall) bearings are also available; please contact NSK for details.
 2. When using bearings with rotating outer rings, contact NSK if they are sealed, shielded, or have snap rings.
 3. Bearings denoted by an asterisk (*) are NSKHPS™ deep groove ball bearings.

SINGLE-ROW DEEP GROOVE BALL BEARINGS

Bore Diameter 50 – 60 mm

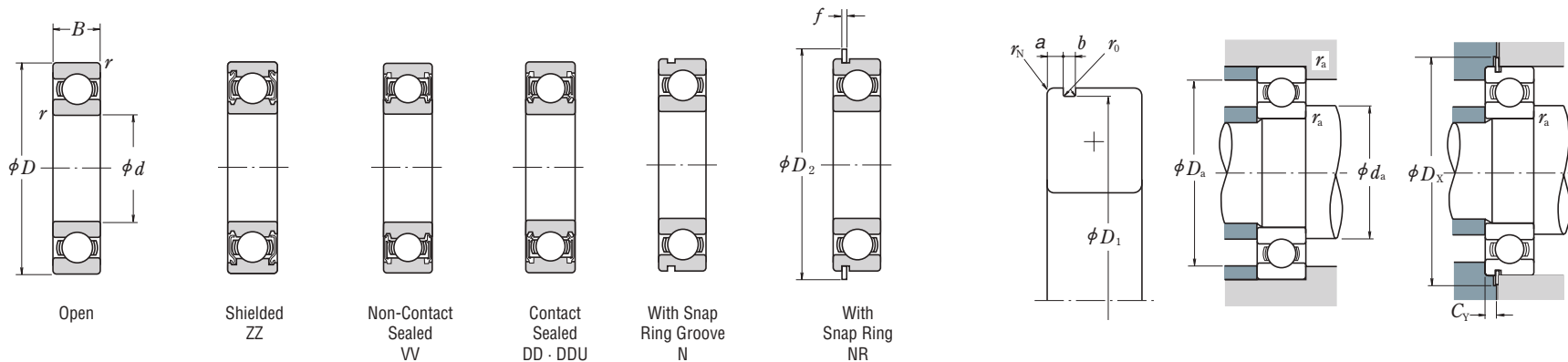

Dynamic Equivalent Load

$$P = XF_r + YF_a$$

$\frac{f_0 F_a}{C_{0r}}$	e	$\frac{F_a}{F_r} \leq e$		$\frac{F_a}{F_r} > e$	
		X	Y	X	Y
0.172	0.19	1	0	0.56	2.30
0.345	0.22	1	0	0.56	1.99
0.689	0.26	1	0	0.56	1.71
1.03	0.28	1	0	0.56	1.55
1.38	0.30	1	0	0.56	1.45
2.07	0.34	1	0	0.56	1.31
3.45	0.38	1	0	0.56	1.15
5.17	0.42	1	0	0.56	1.04
6.89	0.44	1	0	0.56	1.00

Static Equivalent Load

$$\frac{F_a}{F_r} > 0.8, P_0 = 0.6F_r + 0.5F_a$$

$$\frac{F_a}{F_r} \leq 0.8, P_0 = F_r$$

Boundary Dimensions (mm)	Basic Load Ratings (N)		Factor	Limiting Speeds (min ⁻¹)			Bearing Designations			With Snap Ring Groove		Snap Ring Groove Dimensions (1) (mm)					Snap Ring (1) Dimensions (mm)		Abutment and Fillet Dimensions (mm)					Mass (kg) approx.												
												d	D	B	r min.	C _r	C _{0r}	f ₀	Grease	Oil	Open	Shielded	Sealed		a max.	b min.	D ₁ max.	r ₀ max.	r _N min.	D ₂ max.	f max.	d _a (2) min.	D _a (2) max.	r _a max.	D _x min.	C _y max.
50	65	7	0.3	6 400	6 200	17.2	9 500	5 300	11 000	6810	ZZ	VV	DDU	N	NR	1.30	0.95	63.7	0.25	0.3	67.8	0.85	52	52.5	63	0.3	68.5	1.8	0.050							
	72	12	0.6	14 500	11 700	16.1	9 000	5 300	11 000	6910	ZZ	VV	DDU	N	NR	1.70	0.95	70.7	0.25	0.5	74.8	0.85	54	55	68	0.6	76	2.3	0.135							
	80	10	0.6	15 400	12 400	16.1	8 500	—	10 000	16010	—	—	—	—	—	—	—	—	—	—	—	54	—	76	0.6	—	—	0.175								
	80	16	1	22 900	16 600	15.6	9 500	4 800	11 000	* 6010	ZZ	VV	DDU	—	—	—	—	—	—	—	—	—	55	58.5	75	1	—	—	0.261							
	80	16	1	21 800	16 600	15.6	8 500	4 800	10 000	6010	ZZ	VV	DDU	N	NR	2.49	1.9	76.81	0.6	0.5	86.6	1.7	55	58.5	75	1	88	3.8	0.261							
	80	20	1.1	37 000	23 200	14.4	8 000	4 800	10 000	* 6210	ZZ	VV	DDU	—	—	—	—	—	—	—	—	—	56.5	60	83.5	1	—	—	0.459							
	90	20	1.1	35 000	23 200	14.4	7 100	4 800	8 500	* 6210	ZZ	VV	DDU	N	NR	3.28	2.7	86.79	0.6	0.5	96.5	2.46	56.5	60	83.5	1	98	5.4	0.459							
	110	27	2	65 000	38 500	13.2	7 100	4 300	8 500	* 6310	ZZ	VV	DDU	—	—	—	—	—	—	—	—	—	59	68	101	2	—	—	1.06							
	110	27	2	62 000	38 500	13.2	6 000	4 300	7 500	6310	ZZ	VV	DDU	N	NR	3.28	2.7	106.81	0.6	0.5	116.6	2.46	59	68	101	2	118	5.4	1.06							
	55	72	9	0.3	8 800	8 500	17.0	8 500	4 800	10 000	6811	ZZ	VV	DDU	N	NR	1.70	0.95	70.7	0.25	0.3	74.8	0.85	57	59	70	0.3	76	2.3	0.081						
		80	13	1	16 000	13 300	16.2	8 000	4 500	9 500	6911	ZZ	VV	DDU	N	NR	2.10	1.3	77.9	0.4	0.5	84.4	1.12	60	61.5	75	1	86	2.9	0.189						
		90	11	0.6	19 400	16 300	16.2	7 500	—	9 000	16011	—	—	—	—	—	—	—	—	—	—	—	59	—	86	0.6	—	—	0.257							
90		18	1.1	29 700	21 200	15.3	8 500	4 500	10 000	* 6011	ZZ	VV	DDU	—	—	—	—	—	—	—	—	—	61.5	64	83.5	1	—	—	0.381							
90		18	1.1	28 300	21 200	15.3	7 500	4 500	9 000	6011	ZZ	VV	DDU	N	NR	2.87	2.7	86.79	0.6	0.5	96.5	2.46	61.5	64	83.5	1	98	5	0.381							
100		21	1.5	45 500	29 300	14.3	7 500	4 300	9 000	* 6211	ZZ	VV	DDU	—	—	—	—	—	—	—	—	—	63	66.5	92	1.5	—	—	0.619							
100		21	1.5	43 500	29 300	14.3	6 300	4 300	7 500	* 6211	ZZ	VV	DDU	N	NR	3.28	2.7	96.8	0.6	0.5	106.5	2.46	63	66.5	92	1.5	108	5.4	0.619							
120		29	2	75 000	44 500	13.1	6 700	4 000	8 000	* 6311	ZZ	VV	DDU	—	—	—	—	—	—	—	—	—	64	72.5	111	2	—	—	1.37							
120		29	2	71 500	44 500	13.1	5 600	4 000	6 700	6311	ZZ	VV	DDU	N	NR	4.06	3.1	115.21	0.6	0.5	129.7	2.82	64	72.5	111	2	131.5	6.5	1.37							
60		78	10	0.3	11 500	10 900	16.9	8 000	4 500	9 500	6812	ZZ	VV	DD	N	NR	1.70	1.3	76.2	0.4	0.3	82.7	1.12	62	64	76	0.3	84	2.5	0.103						
		85	13	1	19 400	16 300	16.2	7 500	4 300	9 000	6912	ZZ	VV	DDU	N	NR	2.10	1.3	82.9	0.4	0.5	89.4	1.12	65	66	80	1	91	2.9	0.192						
		95	11	0.6	20 000	17 500	16.3	7 100	—	8 500	16012	—	—	—	—	—	—	—	—	—	—	—	64	—	91	0.6	—	—	0.281							
	95	18	1.1	31 000	23 200	15.6	8 000	4 000	9 500	* 6012	ZZ	VV	DDU	—	—	—	—	—	—	—	—	—	66.5	69	88.5	1	—	—	0.412							
	95	18	1.1	29 500	23 200	15.6	7 100	4 000	8 500	6012	ZZ	VV	DDU	N	NR	2.87	2.7	91.82	0.6	0.5	101.6	2.46	66.5	69	88.5	1	103	5	0.412							
	110	22	1.5	55 000	36 000	14.3	6 700	3 800	8 000	* 6212	ZZ	VV	DDU	—	—	—	—	—	—	—	—	—	68	74.5	102	1.5	—	—	0.783							
	110	22	1.5	52 500	36 000	14.3	5 600	3 800	7 100	* 6212	ZZ	VV	DDU	N	NR	3.28	2.7	106.81	0.6	0.5	116.6	2.46	68	74.5	102	1.5	118	5.4	0.783							
	130	31	2.1	86 000	52 000	13.1	6 000	3 600	7 100	* 6312	ZZ	VV	DDU	—	—	—	—	—	—	—	—	—	71	79	119	2	—	—	1.72							
	130	31	2.1	82 000	52 000	13.1	5 300	3 600	6 300	6312	ZZ	VV	DDU	N	NR	4.06	3.1	125.22	0.6	0.5	139.7	2.82	71	79	119	2	141.5	6.5	1.72							

Notes (1) For tolerances of snap ring grooves and snap ring dimensions, refer to Pages A116 to A119.
 (2) When heavy axial loads are applied, d_a and D_a can be adjusted up to the shoulder diameter of the races. Please consult NSK for details.

Remarks 1. Diameter Series 7 (extra-thin wall) bearings are also available; please contact NSK for details.
 2. When using bearings with rotating outer rings, contact NSK if they are sealed, shielded, or have snap rings.
 3. Please consult NSK about the snap ring groove dimensions of Dimension Series 18 and 19 sealed and shielded bearings when the diameter is 50 mm or more.
 4. Bearings denoted by an asterisk (*) are NSKHPST™ deep groove ball bearings.

■ SINGLE-ROW DEEP GROOVE BALL BEARINGS

Bore Diameter 65 – 75 mm

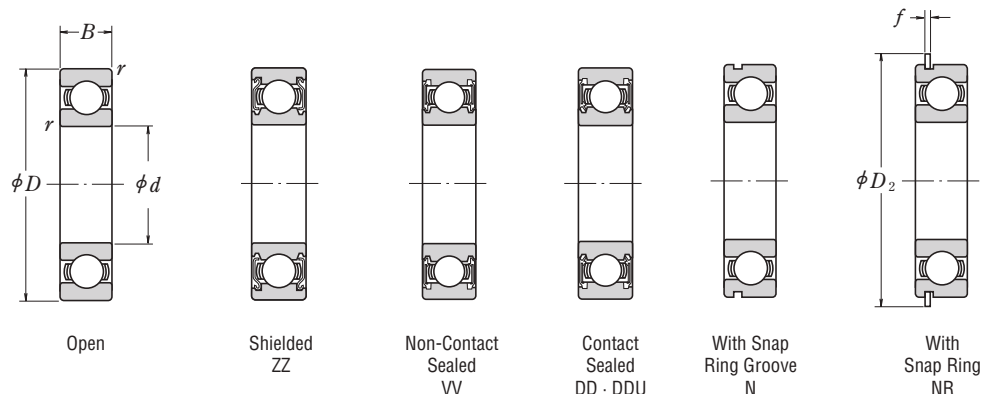

Dynamic Equivalent Load

$$P = XF_r + YF_a$$

$\frac{f_0 F_a}{C_{0r}}$	e	$\frac{F_a}{F_r} \leq e$		$\frac{F_a}{F_r} > e$	
		X	Y	X	Y
0.172	0.19	1	0	0.56	2.30
0.345	0.22	1	0	0.56	1.99
0.689	0.26	1	0	0.56	1.71
1.03	0.28	1	0	0.56	1.55
1.38	0.30	1	0	0.56	1.45
2.07	0.34	1	0	0.56	1.31
3.45	0.38	1	0	0.56	1.15
5.17	0.42	1	0	0.56	1.04
6.89	0.44	1	0	0.56	1.00

Static Equivalent Load

$$\frac{F_a}{F_r} > 0.8, P_0 = 0.6F_r + 0.5F_a$$

$$\frac{F_a}{F_r} \leq 0.8, P_0 = F_r$$

Boundary Dimensions (mm)				Basic Load Ratings (N)		Factor f_0	Limiting Speeds (min ⁻¹)			Bearing Designations			With Snap Ring Groove	With Snap Ring	Snap Ring Groove Dimensions (1) (mm)					Snap Ring (1) Dimensions (mm)		Abutment and Fillet Dimensions (mm)					Mass (kg) approx.					
d	D	B	r_{min}	C_r	C_{0r}		Grease		Oil	Open	Shielded	Sealed			a	b	D_1	r_0	r_N	D_2	f	d_a (2)	D_a (2)	r_a	D_x	C_y						
65	85	10	0.6	11 900	12 100	17.0	7 500	4 000	8 500	6813	ZZ	VV	DD	N	NR	1.70	1.3	82.9	0.4	0.5	89.4	1.12	69	69	81	0.6	91	2.5	0.128			
	90	13	1	17 400	16 100		7 100	4 000	8 500		6913	ZZ	VV			DDU	N	NR	2.10	1.3	87.9	0.4	0.5	94.4	1.12	70	71.5	85	1	96	2.9	0.218
	100	11	0.6	20 500	18 700		6 700	—	8 000		16013	—	—			—	—	—	—	—	—	—	—	—	—	—	—	—	—	—	—	—
100	18	1.1	32 000	25 200	15.8	7 500	4 000	9 000	*	6013	ZZ	VV	DDU	N	NR	—	—	—	—	—	—	—	71.5	73	93.5	1	—	—	0.439			
	100	18	1.1	30 500		25 200	6 700	4 000	8 000	6013	ZZ	VV	DDU			N	NR	2.87	2.7	96.8	0.6	0.5	106.5	2.46	71.5	73	93.5	1	108	5	0.439	
	120	23	1.5	60 000		40 000	6 300	3 600	7 500	* 6213	ZZ	VV	DDU			—	—	—	—	—	—	—	—	—	—	—	—	—	—	—	—	1.0
120	23	1.5	57 500	40 000	14.4	5 300	3 600	6 300	*	6213	ZZ	VV	DDU	N	NR	4.06	3.1	115.21	0.6	0.5	129.7	2.82	73	80	112	1.5	131.5	6.5	1.0			
	140	33	2.1	97 500		60 000	5 600	3 400	6 700	* 6313	ZZ	VV	DDU			N	NR	—	—	—	—	—	—	—	—	—	—	—	—	—	2.11	
	140	33	2.1	92 500		60 000	4 800	3 400	6 000	6313	ZZ	VV	DDU			N	NR	4.90	3.1	135.23	0.6	0.5	149.7	2.82	76	85.5	129	2	—	—	—	2.11
70	90	10	0.6	12 100	12 700	17.2	6 700	3 800	8 000	6814	ZZ	VV	DD	N	NR	1.70	1.3	87.9	0.4	0.5	94.4	1.12	74	74.5	86	0.6	96	2.5	0.134			
	100	16	1	23 700	21 200		6 300	3 600	7 500		6914	ZZ	VV			DDU	N	NR	2.50	1.3	97.9	0.4	0.5	104.4	1.12	75	77.5	95	1	106	3.3	0.349
	110	13	0.6	26 800	23 600		6 000	—	7 100		16014	—	—			—	—	—	—	—	—	—	—	—	—	—	—	—	—	—	—	0.441
110	20	1.1	40 000	31 000	15.6	7 100	3 600	8 500	*	6014	ZZ	VV	DDU	N	NR	—	—	—	—	—	—	—	76.5	80.5	103.5	1	—	—	0.608			
	110	20	1.1	38 000		31 000	6 000	3 600	7 100	6014	ZZ	VV	DDU			N	NR	2.87	2.7	106.81	0.6	0.5	116.6	2.46	76.5	80.5	103.5	1	118	5	0.608	
	125	24	1.5	65 500		44 000	6 000	3 400	7 100	* 6214	ZZ	VV	DDU			—	—	—	—	—	—	—	—	—	—	—	—	—	—	—	1.09	
125	24	1.5	62 000	44 000	14.5	5 000	3 400	6 300	*	6214	ZZ	VV	DDU	N	NR	4.06	3.1	120.22	0.6	0.5	134.7	2.82	78	84	117	1.5	136.5	6.5	1.09			
	150	35	2.1	109 000		68 000	5 300	3 200	6 300	* 6314	ZZ	VV	DDU			N	NR	—	—	—	—	—	—	—	—	—	—	—	—	—	2.57	
	150	35	2.1	104 000		68 000	4 500	3 200	5 300	6314	ZZ	VV	DDU			N	NR	4.90	3.1	145.24	0.6	0.5	159.7	2.82	81	92	139	2	—	—	—	2.57
75	95	10	0.6	12 500	13 900	17.3	6 300	3 600	7 500	6815	ZZ	VV	DDU	N	NR	1.70	1.3	92.9	0.4	0.5	99.4	1.12	79	79.5	91	0.6	101	2.5	0.149			
	105	16	1	24 400	22 600		6 000	3 400	7 100		6915	ZZ	VV			DDU	N	NR	2.50	1.3	102.6	0.4	0.5	110.7	1.12	80	82	100	1	112	3.3	0.364
	115	13	0.6	27 600	25 300		5 600	—	6 700		16015	—	—			—	—	—	—	—	—	—	—	—	—	—	—	—	—	—	—	0.463
115	20	1.1	41 500	33 500	15.8	6 700	3 400	8 000	*	6015	ZZ	VV	DDU	N	NR	—	—	—	—	—	—	—	81.5	85.5	108.5	1	—	—	0.649			
	115	20	1.1	39 500		33 500	5 600	3 400	6 700	6015	ZZ	VV	DDU			N	NR	2.87	2.7	111.81	0.6	0.5	121.6	2.46	81.5	85.5	108.5	1	123	5	0.649	
	130	25	1.5	69 500		49 500	5 600	3 200	6 700	* 6215	ZZ	VV	DDU			—	—	—	—	—	—	—	—	—	—	—	—	—	—	—	1.19	
130	25	1.5	66 000	49 500	14.7	4 800	3 200	5 600	*	6215	ZZ	VV	DDU	N	NR	4.06	3.1	125.22	0.6	0.5	139.7	2.82	83	90	122	1.5	141.5	6.5	1.19			
	160	37	2.1	119 000		77 000	4 800	2 800	6 000	* 6315	ZZ	VV	DDU			N	NR	—	—	—	—	—	—	—	—	—	—	—	—	—	3.08	
	160	37	2.1	113 000		77 000	4 300	2 800	5 000	6315	ZZ	VV	DDU			N	NR	4.90	3.1	155.22	0.6	0.5	169.7	2.82	86	98.5	149	2	172	7.3	3.08	

Notes (1) For tolerances of snap ring grooves and snap ring dimensions, refer to Pages A116 to A119.
 (2) When heavy axial loads are applied, d_a and D_a can be adjusted up to the shoulder diameter of the races. Please consult NSK for details.

Remarks 1. Diameter Series 7 (extra-thin wall) bearings are also available; please contact NSK for details.
 2. When using bearings with rotating outer rings, contact NSK if they are sealed, shielded, or have snap rings.
 3. Please consult NSK about the snap ring groove dimensions of Dimension Series 18 and 19 sealed and shielded bearings when the diameter is 50 mm or more.
 4. Bearings denoted by an asterisk (*) are NSKHPST™ deep groove ball bearings.

SINGLE-ROW DEEP GROOVE BALL BEARINGS

Bore Diameter 80 – 90 mm

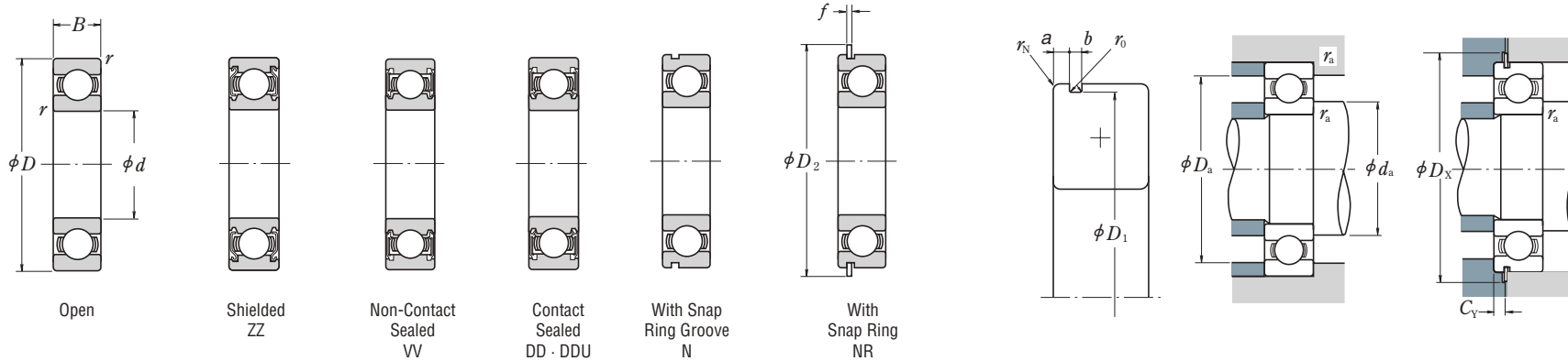

Dynamic Equivalent Load

$$P = XF_r + YF_a$$

$\frac{f_0 F_a}{C_{0r}}$	e	$\frac{F_a}{F_r} \leq e$		$\frac{F_a}{F_r} > e$	
		X	Y	X	Y
		0.172	0.19	1	0
0.345	0.22	1	0	0.56	1.99
0.689	0.26	1	0	0.56	1.71
1.03	0.28	1	0	0.56	1.55
1.38	0.30	1	0	0.56	1.45
2.07	0.34	1	0	0.56	1.31
3.45	0.38	1	0	0.56	1.15
5.17	0.42	1	0	0.56	1.04
6.89	0.44	1	0	0.56	1.00

Static Equivalent Load

$$\frac{F_a}{F_r} > 0.8, P_0 = 0.6F_r + 0.5F_a$$

$$\frac{F_a}{F_r} \leq 0.8, P_0 = F_r$$

Boundary Dimensions (mm)	Basic Load Ratings (N)		Factor	Limiting Speeds (min ⁻¹)			Bearing Designations			With Snap Ring Groove		Snap Ring Groove Dimensions (1) (mm)					Snap Ring (1) Dimensions (mm)		Abutment and Fillet Dimensions (mm)					Mass (kg)						
												Open	Shielded	Sealed	a	b	D ₁	r ₀	r _N	D ₂	f	d _a (2)	D _a (2)		r _a	D _x	C _y			
																												max.	min.	max.
80	100	10	0.6	12 700	14 500	17.4	6 000	3 400	7 100	6816	ZZ	VV	DDU	N	NR	1.7	1.3	97.9	0.4	0.5	104.4	1.12	84	84.5	96	0.6	106	2.5	0.151	
	110	16	1	25 000	24 000	16.6	5 600	3 200	6 700	6916	ZZ	VV	DDU	N	NR	2.5	1.3	107.6	0.4	0.5	115.7	1.12	85	87.5	105	1	117	3.3	0.391	
	125	14	0.6	32 000	29 600	16.4	5 300	—	6 300	16016	—	—	—	—	—	—	—	—	—	—	—	—	—	—	—	—	—	—	0.621	
	125	22	1.1	50 000	40 000	15.6	6 300	3 200	7 100	* 6016	ZZ	VV	DDU	—	—	—	—	—	—	—	—	—	86.5	91	118.5	1	—	—	—	0.872
	125	22	1.1	47 500	40 000	15.6	5 300	3 200	6 300	* 6016	ZZ	VV	DDU	N	NR	2.87	3.1	120.22	0.6	0.5	134.7	2.82	86.5	91	118.5	1	136.5	5.3	0.872	
	140	26	2	76 500	53 000	14.6	5 300	3 000	6 300	* 6216	ZZ	VV	DDU	—	—	—	—	—	—	—	—	—	89	95.5	131	2	—	—	—	1.42
	140	26	2	72 500	53 000	14.6	4 500	3 000	5 300	* 6216	ZZ	VV	DDU	N	NR	4.90	3.1	135.23	0.6	0.5	149.7	2.82	89	95.5	131	2	152	7.3	1.42	
	170	39	2.1	129 000	86 500	13.3	4 500	2 800	5 600	* 6316	ZZ	VV	DDU	N	NR	5.69	3.5	163.65	0.6	0.5	182.9	3.1	91	104.5	159	2	—	—	—	3.67
	170	39	2.1	123 000	86 500	13.3	4 000	2 800	4 800	* 6316	ZZ	VV	DDU	N	NR	5.69	3.5	163.65	0.6	0.5	182.9	3.1	91	104.5	159	2	185	8.4	3.67	
	85	110	13	1	18 700	20 000	17.1	5 600	3 200	6 700	6817	ZZ	VV	DDU	N	NR	2.10	1.3	107.6	0.4	0.5	115.7	1.12	90	90.5	105	1	117	2.9	0.263
		120	18	1.1	32 000	29 600	16.4	5 300	3 000	6 300	6917	ZZ	VV	DDU	N	NR	3.30	1.3	117.6	0.4	0.5	125.7	1.12	91.5	94.5	113.5	1	127	4.1	0.55
		130	14	0.6	33 000	31 500	16.5	5 000	—	6 000	16017	—	—	—	—	—	—	—	—	—	—	—	—	—	—	—	—	—	—	0.652
130		22	1.1	52 000	43 000	15.8	6 000	3 000	7 100	* 6017	ZZ	VV	DDU	—	—	—	—	—	—	—	—	—	91.5	96	123.5	1	—	—	—	0.918
130		22	1.1	49 500	43 000	15.8	5 000	3 000	6 000	* 6017	ZZ	VV	DDU	N	NR	2.87	3.1	125.22	0.6	0.5	139.7	2.82	91.5	96	123.5	1	141.5	5.3	0.918	
150		28	2	88 000	62 000	14.5	4 800	2 800	6 000	* 6217	ZZ	VV	DDU	—	—	—	—	—	—	—	—	—	94	102	141	2	—	—	—	1.76
150		28	2	84 000	62 000	14.5	4 300	2 800	5 000	* 6217	ZZ	VV	DDU	N	NR	4.90	3.1	145.24	0.6	0.5	159.7	2.82	94	102	141	2	162	7.3	1.76	
180		41	3	139 000	97 000	13.3	4 300	2 600	5 000	* 6317	ZZ	VV	DDU	N	NR	5.69	3.5	173.66	0.6	0.5	192.9	3.1	98	110.5	167	2.5	—	—	—	4.28
180		41	3	133 000	97 000	13.3	3 800	2 600	4 500	* 6317	ZZ	VV	DDU	N	NR	5.69	3.5	173.66	0.6	0.5	192.9	3.1	98	110.5	167	2.5	195	8.4	4.28	
90		115	13	1	19 000	21 000	17.2	5 300	3 000	6 300	6818	ZZ	VV	DDU	N	NR	2.10	1.3	112.6	0.4	0.5	120.7	1.12	95	95.5	110	1	122	2.9	0.276
		125	18	1.1	33 000	31 500	16.5	5 000	2 800	6 000	6918	ZZ	VV	DDU	N	NR	3.30	1.3	122.6	0.4	0.5	130.7	1.12	96.5	98.5	118.5	1	132	4.1	0.585
		140	16	1	41 500	39 500	16.3	4 800	—	5 600	16018	—	—	—	—	—	—	—	—	—	—	—	—	95	—	135	1	—	—	—
	140	24	1.5	61 000	50 000	15.6	5 600	2 800	6 300	* 6018	ZZ	VV	DDU	—	—	—	—	—	—	—	—	—	98	103	132	1.5	—	—	—	1.19
	140	24	1.5	58 000	50 000	15.6	4 800	2 800	5 600	* 6018	ZZ	VV	DDU	N	NR	3.71	3.1	135.23	0.6	0.5	149.7	2.82	98	103	132	1.5	152	6.1	1.19	
	160	30	2	101 000	71 500	14.5	4 500	2 600	5 600	* 6218	ZZ	VV	DDU	—	—	—	—	—	—	—	—	—	99	107.5	151	2	—	—	—	2.18
	160	30	2	96 000	71 500	14.5	4 000	2 600	4 800	* 6218	ZZ	VV	DDU	N	NR	4.90	3.1	155.22	0.6	0.5	169.7	2.82	99	107.5	151	2	172	7.3	2.18	
	190	43	3	150 000	107 000	13.3	4 000	2 400	4 800	* 6318	ZZ	VV	DDU	N	NR	5.69	3.5	183.64	0.6	0.5	202.9	3.1	103	117	177	2.5	—	—	—	4.98
	190	43	3	143 000	107 000	13.3	3 600	2 400	4 300	* 6318	ZZ	VV	DDU	N	NR	5.69	3.5	183.64	0.6	0.5	202.9	3.1	103	117	177	2.5	205	8.4	4.98	

Notes (1) For tolerances of snap ring grooves and snap ring dimensions, refer to Pages A116 to A119.
 (2) When heavy axial loads are applied, d_a and D_a can be adjusted up to the shoulder diameter of the races. Please consult NSK for details.

Remarks 1. Diameter Series 7 (extra-thin wall) bearings are also available; please contact NSK for details.
 2. When using bearings with rotating outer rings, contact NSK if they are sealed, shielded, or have snap rings.
 3. Please consult NSK about the snap ring groove dimensions of Dimension Series 18 and 19 sealed and shielded bearings when the diameter is 50 mm or more.
 4. Bearings denoted by an asterisk (*) are NSKHPST™ deep groove ball bearings.

■ SINGLE-ROW DEEP GROOVE BALL BEARINGS

Bore Diameter 95 – 105 mm

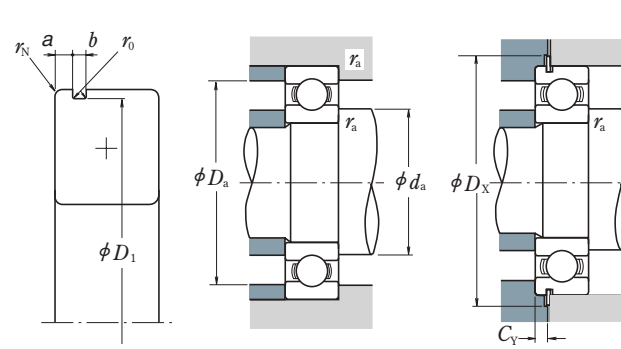
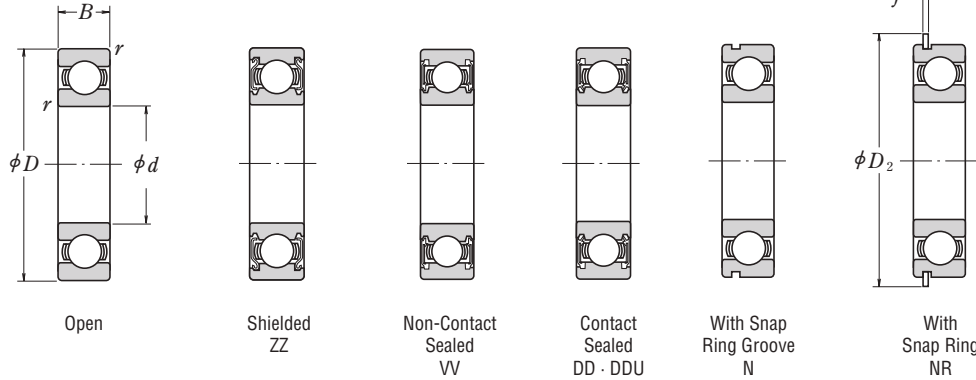

Dynamic Equivalent Load

$P = X F_r + Y F_a$

$\frac{f_0 F_a}{C_{0r}}$	e	$\frac{F_a}{F_r} \leq e$		$\frac{F_a}{F_r} > e$	
		X	Y	X	Y
0.172	0.19	1	0	0.56	2.30
0.345	0.22	1	0	0.56	1.99
0.689	0.26	1	0	0.56	1.71
1.03	0.28	1	0	0.56	1.55
1.38	0.30	1	0	0.56	1.45
2.07	0.34	1	0	0.56	1.31
3.45	0.38	1	0	0.56	1.15
5.17	0.42	1	0	0.56	1.04
6.89	0.44	1	0	0.56	1.00

Static Equivalent Load

$\frac{F_a}{F_r} > 0.8, P_0 = 0.6 F_r + 0.5 F_a$

$\frac{F_a}{F_r} \leq 0.8, P_0 = F_r$

Boundary Dimensions (mm)	Basic Load Ratings (N)		Factor	Limiting Speeds (min ⁻¹)			Bearing Designations			With Snap Ring Groove	With Snap Ring	Snap Ring Groove Dimensions (1) (mm)					Snap Ring (1) Dimensions (mm)		Abutment and Fillet Dimensions (mm)					Mass (kg) approx.									
												C_r	C_{0r}	f_0	Grease			Oil			a max.	b min.	D_1 max.		r_0 max.	r_N min.	D_2 max.	f max.	d_a (2) min.	D_a (2) max.	r_a max.	D_x min.	C_Y max.
															Open Z	ZZ V	ZZ VV	DU DDU	Open Z	Open													
95	120	13	1	19 300	22 000	17.2	5 000	2 800	6 000	6819 ZZ VV DD	N	NR	2.10	1.3	117.6	0.4	0.5	125.7	1.12	100	101.5	115	1	127	2.9	0.297							
	130	18	1.1	33 500	33 500	16.6	4 800	2 800	5 600	6919 ZZ VV DDU	N	NR	3.30	1.3	127.6	0.4	0.5	135.7	1.12	101.5	103.5	123.5	1	137	4.1	0.601							
	145	16	1	43 000	42 000	16.4	4 500	—	5 300	16019 — — —	—	—	—	—	—	—	—	—	—	100	—	140	1	—	—	0.904							
	145	24	1.5	63 500	54 000	15.8	5 300	2 600	6 000	* 6019 ZZ VV DDU	—	—	—	—	—	—	—	—	—	103	108.5	137	1.5	—	—	1.23							
	145	24	1.5	60 500	54 000	15.8	4 500	2 600	5 300	6019 ZZ VV DDU	N	NR	3.71	3.1	140.23	0.6	0.5	154.7	2.82	103	108.5	137	1.5	157	6.1	1.23							
	170	32	2.1	114 000	82 000	14.4	4 300	2 600	5 000	* 6219 ZZ VV DDU	—	—	—	—	—	—	—	—	—	106	114	159	2	—	—	2.64							
	170	32	2.1	109 000	82 000	14.4	3 800	2 600	4 500	6219 ZZ VV DDU	N	NR	5.69	3.5	163.65	0.6	0.5	182.9	3.1	106	114	159	2	185	8.4	2.64							
	200	45	3	160 000	119 000	13.3	3 400	2 400	4 300	* 6319 ZZ VV DDU	—	—	—	—	—	—	—	—	—	108	123.5	187	2.5	—	—	5.76							
	200	45	3	153 000	119 000	13.3	3 000	2 400	3 600	6319 ZZ VV DDU	N	NR	5.69	3.5	193.65	0.6	0.5	212.9	3.1	108	123.5	187	2.5	215	8.4	5.76							
100	125	13	1	19 600	23 000	17.3	4 800	2 800	5 600	6820 ZZ VV DD	N	NR	2.10	1.3	122.6	0.4	0.5	130.7	1.12	105	105.5	120	1	132	2.9	0.31							
	140	20	1.1	43 000	42 000	16.4	4 500	2 600	5 300	6920 ZZ VV DDU	N	NR	3.30	1.9	137.6	0.6	0.5	145.7	1.7	106.5	111	133.5	1	147	4.7	0.828							
	150	16	1	42 500	42 000	16.5	4 300	—	5 300	16020 — — —	—	—	—	—	—	—	—	—	—	105	—	145	1	—	—	0.945							
	150	24	1.5	63 000	54 000	15.9	5 000	2 600	6 000	* 6020 ZZ VV DDU	—	—	—	—	—	—	—	—	—	108	112.5	142	1.5	—	—	1.29							
	150	24	1.5	60 000	54 000	15.9	4 300	2 600	5 300	6020 ZZ VV DDU	N	NR	3.71	3.1	145.24	0.6	0.5	159.7	2.82	108	112.5	142	1.5	162	6.1	1.29							
	180	34	2.1	128 000	93 000	14.4	4 000	2 400	4 800	* 6220 ZZ VV DDU	—	—	—	—	—	—	—	—	—	111	121.5	169	2	—	—	3.17							
	180	34	2.1	122 000	93 000	14.4	3 600	2 400	4 300	6220 ZZ VV DDU	N	NR	5.69	3.5	173.66	0.6	0.5	192.9	3.1	111	121.5	169	2	195	8.4	3.17							
	215	47	3	173 000	141 000	13.2	2 800	2 200	3 400	6320 ZZ VV DDU	—	—	—	—	—	—	—	—	—	113	133	202	2.5	—	—	7.04							
	105	130	13	1	19 800	23 900	17.4	4 800	2 600	5 600	6821 ZZ VV DDU	N	NR	2.10	1.3	127.6	0.4	0.5	135.7	1.12	110	110.5	125	1	137	2.9	0.324						
145		20	1.1	42 500	42 000	16.5	4 300	—	5 300	6921 ZZ VV —	N	NR	3.30	1.9	142.6	0.6	0.5	150.7	1.7	111.5	116	138.5	1	152	4.7	0.856							
160		18	1	52 000	50 500	16.3	4 000	—	4 800	16021 — — —	—	—	—	—	—	—	—	—	—	110	—	155	1	—	—	1.24							
160		26	2	76 000	66 000	15.8	4 500	2 400	5 600	* 6021 ZZ VV DDU	—	—	—	—	—	—	—	—	—	114	120	151	2	—	—	1.58							
160		26	2	72 500	66 000	15.8	4 000	2 400	4 800	6021 ZZ VV DDU	N	NR	3.71	3.1	155.22	0.6	0.5	169.7	2.82	114	120	151	2	172	6.1	1.58							
190		36	2.1	140 000	105 000	14.4	3 800	2 200	4 500	* 6221 ZZ VV DDU	—	—	—	—	—	—	—	—	—	116	127.5	179	2	—	—	3.79							
190		36	2.1	133 000	105 000	14.4	3 400	2 200	4 000	6221 ZZ VV DDU	N	NR	5.69	3.5	183.64	0.6	0.5	202.9	3.1	116	127.5	179	2	205	8.4	3.79							
225		49	3	184 000	154 000	13.2	2 600	2 000	3 200	6321 ZZ — DDU	—	—	—	—	—	—	—	—	—	118	138	212	2.5	—	—	8.09							

- Notes** (1) For tolerances of snap ring grooves and snap ring dimensions, refer to Pages A116 to A119.
 (2) When heavy axial loads are applied, d_a and D_a can be adjusted up to the shoulder diameter of the races. Please consult NSK for details.

- Remarks** 1. Diameter Series 7 (extra-thin wall) bearings are also available; please contact NSK for details.
 2. When using bearings with rotating outer rings, contact NSK if they are sealed, shielded, or have snap rings.
 3. Please consult NSK about the snap ring groove dimensions of Dimension Series 18 and 19 sealed and shielded bearings when the diameter is 50 mm or more.
 4. Bearings denoted by an asterisk (*) are NSKHPS™ deep groove ball bearings.

■ SINGLE-ROW DEEP GROOVE BALL BEARINGS

Bore Diameter 160 mm

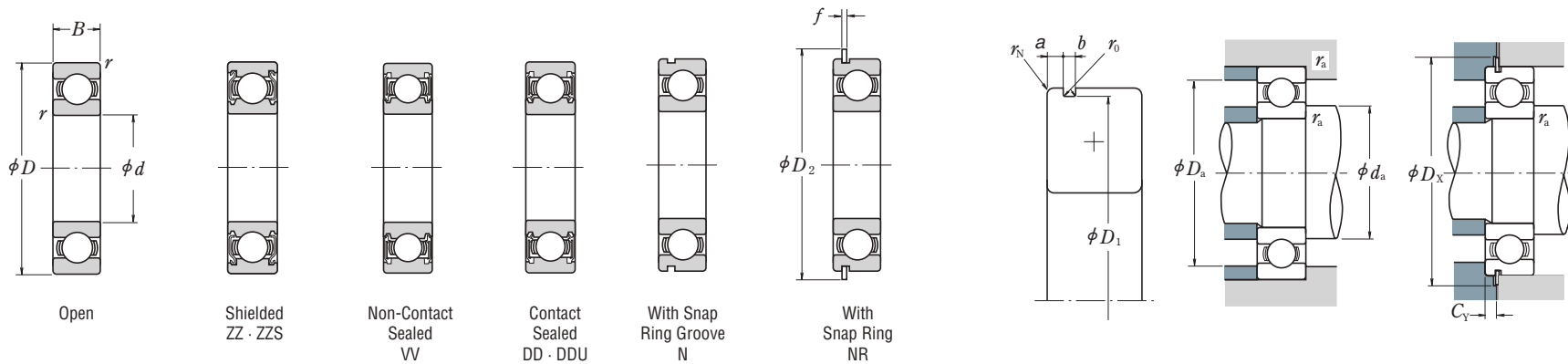

Dynamic Equivalent Load

$$P = XF_r + YF_a$$

$\frac{f_0 F_a}{C_{0r}}$	e	$\frac{F_a}{F_r} \leq e$		$\frac{F_a}{F_r} > e$	
		X	Y	X	Y
0.172	0.19	1	0	0.56	2.30
0.345	0.22	1	0	0.56	1.99
0.689	0.26	1	0	0.56	1.71
1.03	0.28	1	0	0.56	1.55
1.38	0.30	1	0	0.56	1.45
2.07	0.34	1	0	0.56	1.31
3.45	0.38	1	0	0.56	1.15
5.17	0.42	1	0	0.56	1.04
6.89	0.44	1	0	0.56	1.00

Static Equivalent Load

$$\frac{F_a}{F_r} > 0.8, P_0 = 0.6F_r + 0.5F_a$$

$$\frac{F_a}{F_r} \leq 0.8, P_0 = F_r$$

Boundary Dimensions (mm)				Basic Load Ratings (N)		Factor	Limiting Speeds (min ⁻¹)			Bearing Designations			With Snap Ring Groove	With Snap Ring Groove	Snap Ring Groove Dimensions (1) (mm)					Snap Ring (1) Dimensions (mm)		Abutment and Fillet Dimensions (mm)					Mass (kg)		
d	D	B	r min.	C_r	C_{0r}	f_0	Grease		Oil	Open	Shielded	Sealed	N	NR	a max.	b min.	D_1 max.	r_0 max.	r_N min.	D_2 max.	f max.	min.	d_a (2)	D_a (2)	r_a max.	D_x min.	C_γ max.	approx.	
160	200	20	1.1	48 500	61 000	17.2	2 600	1 700	3 200	6832	ZZS	VV	DDU	N	NR	3.30	1.9	196.8	0.6	0.5	206.5	1.7	166.5	170.5	193.5	1	208	4.7	1.23
	220	28	2	87 000	96 000	16.6	2 600	1 600	3 000	6932	ZZS	—	DDU	—	—	—	—	—	—	—	—	—	169	176	211	2	—	—	2.71
	240	25	1.5	99 000	108 000	16.5	2 400	—	2 800	16032	—	—	—	—	—	—	—	—	—	—	—	—	168	—	232	1.5	—	—	4.2
	240	38	2.1	137 000	135 000	15.9	2 400	1 600	2 800	6032	ZZ	—	DDU	—	—	—	—	—	—	—	—	—	171	181.5	229	2	—	—	5.15
	290	48	3	185 000	186 000	15.4	1 900	—	2 400	6232	ZZS	—	—	—	—	—	—	—	—	—	—	—	173	202	277	2.5	—	—	12.8
	340	68	4	278 000	287 000	13.9	1 700	—	2 000	6332	ZZS	—	—	—	—	—	—	—	—	—	—	—	—	176	215.5	324	3	—	—

Notes (1) For tolerances of snap ring grooves and snap ring dimensions, refer to Pages A116 to A119.
 (2) When heavy axial loads are applied, d_a and D_a can be adjusted up to the shoulder diameter of the races. Please consult NSK for details.

Remarks 1. When using bearings with rotating outer rings, contact NSK if they are sealed, shielded, or have snap rings.
 2. Please consult NSK about the snap ring groove dimensions of Dimension Series 18 and 19 sealed and shielded bearings when the diameter is 50 mm or more.

■ SINGLE-ROW DEEP GROOVE BALL BEARINGS

Bore Diameter 170 – 240 mm

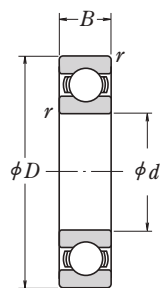

Open



Shielded
ZZS



Non-Contact
Sealed
VV

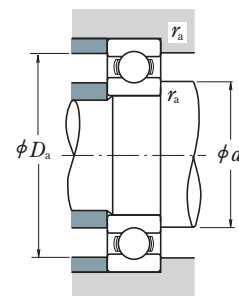

Dynamic Equivalent Load

$$P = XF_r + YF_a$$

$\frac{f_0 F_a}{C_{0r}}$	e	$\frac{F_a}{F_r} \leq e$		$\frac{F_a}{F_r} > e$	
		X	Y	X	Y
0.172	0.19	1	0	0.56	2.30
0.345	0.22	1	0	0.56	1.99
0.689	0.26	1	0	0.56	1.71
1.03	0.28	1	0	0.56	1.55
1.38	0.30	1	0	0.56	1.45
2.07	0.34	1	0	0.56	1.31
3.45	0.38	1	0	0.56	1.15
5.17	0.42	1	0	0.56	1.04
6.89	0.44	1	0	0.56	1.00

Static Equivalent Load

$$\frac{F_a}{F_r} > 0.8, P_0 = 0.6F_r + 0.5F_a$$

$$\frac{F_a}{F_r} \leq 0.8, P_0 = F_r$$

Boundary Dimensions (mm)				Basic Load Ratings (N)		Factor	Limiting Speeds (min ⁻¹)			Bearing Designations			Abutment and Fillet Dimensions (mm)				Mass (kg)	
d	D	B	r min.	C_r	C_{0r}	f_0	Grease		Oil	Open	Shielded	Sealed	$d_{a(1)}$ min.	$d_{a(1)}$ max.	$D_{a(1)}$ max.	r_a max.	approx.	
							Open Z · ZZ V · VV	DU DDU	Open Z									
170	215	22	1.1	60 000	75 000	17.1	2 600	1 600	3 000	6834	ZZS	VV	DDU	176.5	182	208.5	1	1.86
	230	28	2	86 000	97 000	16.7	2 400	—	2 800	6934	ZZS	—	—	179	186	221	2	3.34
	260	28	1.5	114 000	126 000	16.5	2 200	—	2 600	16034	—	—	—	178	—	252	1.5	5.71
	260	42	2.1	161 000	161 000	15.8	2 200	—	2 600	6034	ZZS	VV	—	181	194.5	249	2	6.89
	310	52	4	212 000	224 000	15.3	1 800	—	2 200	6234	ZZS	—	—	186	215	294	3	15.8
180	360	72	4	325 000	355 000	13.6	1 600	—	2 000	6334	—	—	—	186	—	344	3	36.6
	225	22	1.1	60 500	78 500	17.2	2 400	—	2 800	6836	—	VV	—	186.5	192	218.5	1	1.98
	250	33	2	119 000	128 000	16.4	2 200	—	2 600	6936	ZZS	—	—	189	198.5	241	2	4.16
	280	31	2	145 000	157 000	16.3	2 000	—	2 400	16036	—	—	—	189	—	271	2	7.5
	280	46	2.1	180 000	185 000	15.6	2 000	—	2 400	6036	ZZS	VV	—	191	208	269	2	8.88
	320	52	4	227 000	241 000	15.1	1 700	—	2 000	6236	ZZS	—	—	196	223	304	3	15.9
	380	75	4	355 000	405 000	13.9	1 500	—	1 800	6336	—	—	—	196	—	364	3	43.1
190	240	24	1.5	73 000	93 500	17.1	2 200	—	2 600	6838	—	VV	—	198	202.5	232	1.5	2.53
	260	33	2	113 000	127 000	16.6	2 200	—	2 600	6938	—	—	—	199	—	251	2	5.18
	290	31	2	149 000	168 000	16.4	2 000	—	2 400	16038	—	—	—	199	—	281	2	7.78
	290	46	2.1	188 000	201 000	15.8	2 000	—	2 400	6038	ZZS	—	—	201	218	279	2	9.39
	340	55	4	255 000	282 000	15.0	1 600	—	2 000	6238	ZZS	—	—	206	236	324	3	22.3
	400	78	5	355 000	415 000	14.1	1 400	—	1 700	6338	—	—	—	210	—	380	4	49.7
200	250	24	1.5	74 000	98 000	17.2	2 200	—	2 600	6840	—	—	—	208	—	242	1.5	2.67
	280	38	2.1	143 000	158 000	16.4	2 000	—	2 400	6940	ZZS	—	—	211	222	269	2	7.28
	310	34	2	161 000	180 000	16.4	1 900	—	2 200	16040	—	—	—	209	—	301	2	10
	310	51	2.1	207 000	226 000	15.6	1 900	—	2 200	6040	ZZS	—	—	211	231.5	299	2	12
	360	58	4	269 000	310 000	15.2	1 500	—	1 800	6240	ZZS	—	—	216	252	344	3	26.7
	420	80	5	380 000	445 000	13.8	1 300	—	1 600	6340	—	—	—	220	—	400	4	55.3
220	270	24	1.5	76 500	107 000	17.4	1 900	—	2 400	6844	ZZS	—	—	228	233.5	262	1.5	2.9
	300	38	2.1	146 000	169 000	16.6	1 800	—	2 200	6944	ZZS	—	—	231	242	289	2	7.88
	340	37	2.1	180 000	217 000	16.5	1 600	—	2 000	16044	—	—	—	231	—	329	2	13.1
	340	56	3	235 000	271 000	15.6	1 700	—	2 000	6044	ZZS	—	—	233	254.5	327	2.5	18.6
	400	65	4	310 000	375 000	15.1	1 300	—	1 600	6244	—	—	—	236	—	384	3	37.4
240	460	88	5	410 000	520 000	14.3	1 200	—	1 500	6344	—	—	—	240	—	440	4	73.9
	300	28	2	98 500	137 000	17.3	1 700	—	2 000	6848	—	—	—	249	—	291	2	4.48
	320	38	2.1	154 000	190 000	16.8	1 700	—	2 000	6948	ZZS	—	—	251	262	309	2	8.49
	360	37	2.1	196 000	243 000	16.5	1 500	—	1 900	16048	—	—	—	251	—	349	2	13.9
	360	56	3	244 000	296 000	15.9	1 500	—	1 900	6048	—	—	—	253	—	347	2.5	19.9
	440	72	4	340 000	430 000	15.2	1 200	—	1 500	6248	—	—	—	256	—	424	3	50.5
	500	95	5	470 000	625 000	14.2	1 100	—	1 300	6348	—	—	—	260	—	480	4	94.4

Note (1) When heavy axial loads are applied, d_a and D_a can be adjusted up to the shoulder diameter of the races. Please consult NSK for details.

Remark When using bearings with rotating outer rings, contact NSK if they are sealed or shielded.

■ SINGLE-ROW DEEP GROOVE BALL BEARINGS

Bore Diameter 260 – 360 mm

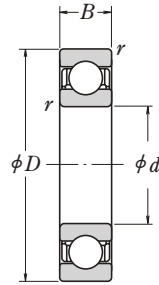

Open

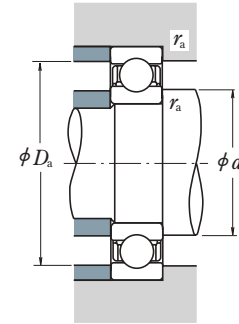

Dynamic Equivalent Load

$$P = XF_r + YF_a$$

$\frac{f_0 F_a}{C_{0r}}$	e	$\frac{F_a}{F_r} \leq e$		$\frac{F_a}{F_r} > e$	
		X	Y	X	Y
0.172	0.19	1	0	0.56	2.30
0.345	0.22	1	0	0.56	1.99
0.689	0.26	1	0	0.56	1.71
1.03	0.28	1	0	0.56	1.55
1.38	0.30	1	0	0.56	1.45
2.07	0.34	1	0	0.56	1.31
3.45	0.38	1	0	0.56	1.15
5.17	0.42	1	0	0.56	1.04
6.89	0.44	1	0	0.56	1.00

Static Equivalent Load

$$\frac{F_a}{F_r} > 0.8, P_0 = 0.6F_r + 0.5F_a$$

$$\frac{F_a}{F_r} \leq 0.8, P_0 = F_r$$

Boundary Dimensions (mm)				Basic Load Ratings (N)		Factor f_0	Limiting Speeds (min ⁻¹)		Bearing Designations Open	Abutment and Fillet Dimensions (mm)			Mass (kg) approx.
d	D	B	r min.	C_r	C_{0r}		Grease	Oil		$d_a^{(1)}$ min.	$D_a^{(1)}$ max.	r_a max.	
260	320	28	2	101 000	148 000	17.4	1 600	1 900	6852	269	311	2	4.84
	360	46	2.1	204 000	255 000	16.5	1 500	1 800	6952	271	349	2	14
	400	44	3	237 000	310 000	16.4	1 400	1 700	16052	273	387	2.5	21.1
	400	65	4	291 000	375 000	15.8	1 400	1 700	6052	276	384	3	29.4
	480	80	5	400 000	540 000	15.1	1 100	1 300	6252	280	460	4	67
	540	102	6	505 000	710 000	14.6	1 000	1 200	6352	286	514	5	118
280	350	33	2	133 000	191 000	17.3	1 500	1 700	6856	289	341	2	7.2
	380	46	2.1	209 000	272 000	16.6	1 400	1 700	6956	291	369	2	15.1
	420	44	3	243 000	330 000	16.5	1 300	1 600	16056	293	407	2.5	22.7
	420	65	4	300 000	410 000	16.0	1 300	1 600	6056	296	404	3	31.2
	500	80	5	400 000	550 000	15.2	1 000	1 300	6256	300	480	4	70.4
	580	108	6	570 000	840 000	14.5	900	1 100	6356	306	554	5	144
300	380	38	2.1	166 000	233 000	17.1	1 300	1 600	6860	311	369	2	10.3
	420	56	3	269 000	370 000	16.4	1 300	1 500	6960	313	407	2.5	23.9
	460	50	4	285 000	405 000	16.4	1 200	1 400	16060	316	444	3	31.5
	460	74	4	355 000	500 000	15.8	1 200	1 400	6060	316	444	3	44.2
	540	85	5	465 000	670 000	15.1	950	1 200	6260	320	520	4	87.8
	320	400	38	2.1	168 000	244 000	17.2	1 300	1 500	6864	331	389	2
440		56	3	266 000	375 000	16.5	1 200	1 400	6964	333	427	2.5	25.3
480		50	4	293 000	430 000	16.5	1 100	1 300	16064	336	464	3	33.2
	480	74	4	390 000	570 000	15.7	1 100	1 300	6064	336	464	3	46.5
	580	92	5	530 000	805 000	15.0	850	1 100	6264	340	560	4	111
	340	420	38	2.1	175 000	265 000	17.3	1 200	1 400	6868	351	409	2
460		56	3	273 000	400 000	16.6	1 100	1 300	6968	353	447	2.5	26.6
520		82	5	440 000	660 000	15.6	1 000	1 200	6068	360	500	4	62.3
620	92	6	530 000	820 000	15.3	800	1 000	6268	366	594	5	129	
360	440	38	2.1	192 000	290 000	17.3	1 100	1 300	6872	371	429	2	11.8
	480	56	3	280 000	425 000	16.7	1 100	1 300	6972	373	467	2.5	27.9
	540	82	5	460 000	720 000	15.7	950	1 200	6072	380	520	4	65.3
650	95	6	555 000	905 000	15.4	750	950	6272	386	624	5	145	

Note (1) When heavy axial loads are applied, d_a and D_a can be adjusted up to the shoulder diameter of the races. Please consult NSK for details.

■ SINGLE-ROW DEEP GROOVE BALL BEARINGS

Bore Diameter 380 – 600 mm

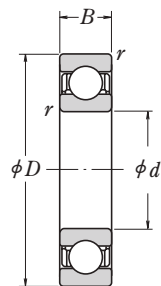

Open

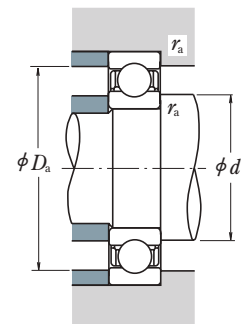

Dynamic Equivalent Load

$$P = XF_r + YF_a$$

$\frac{f_0 F_a}{C_{0r}}$	e	$\frac{F_a}{F_r} \leq e$		$\frac{F_a}{F_r} > e$	
		X	Y	X	Y
0.172	0.19	1	0	0.56	2.30
0.345	0.22	1	0	0.56	1.99
0.689	0.26	1	0	0.56	1.71
1.03	0.28	1	0	0.56	1.55
1.38	0.30	1	0	0.56	1.45
2.07	0.34	1	0	0.56	1.31
3.45	0.38	1	0	0.56	1.15
5.17	0.42	1	0	0.56	1.04
6.89	0.44	1	0	0.56	1.00

Static Equivalent Load

$$\frac{F_a}{F_r} > 0.8, P_0 = 0.6F_r + 0.5F_a$$

$$\frac{F_a}{F_r} \leq 0.8, P_0 = F_r$$

Boundary Dimensions (mm)				Basic Load Ratings (N)		Factor f_0	Limiting Speeds (min ⁻¹)		Bearing Designations Open	Abutment and Fillet Dimensions (mm)			Mass (kg) approx.
d	D	B	r min.	C_r	C_{0r}		Grease	Oil		$d_{a(1)}$ min.	$D_{a(1)}$ max.	r_a max.	
380	480	46	2.1	238 000	375 000	17.1	1 000	1 200	6876	391	469	2	19.5
	520	65	4	325 000	510 000	16.6	950	1 200	6976	396	504	3	40
	560	82	5	455 000	725 000	15.9	900	1 100	6076	400	540	4	68
400	500	46	2.1	241 000	390 000	17.2	950	1 200	6880	411	489	2	20.5
	540	65	4	335 000	540 000	16.7	900	1 100	6980	416	524	3	42
	600	90	5	510 000	825 000	15.7	850	1 000	6080	420	580	4	88.4
420	520	46	2.1	245 000	410 000	17.3	900	1 100	6884	431	509	2	21.4
	560	65	4	340 000	570 000	16.8	900	1 100	6984	436	544	3	43.6
	620	90	5	530 000	895 000	15.8	800	1 000	6084	440	600	4	92.2
440	540	46	2.1	248 000	425 000	17.4	900	1 100	6888	451	529	2	22.3
	600	74	4	395 000	680 000	16.6	800	1 000	6988	456	584	3	60.2
	650	94	6	550 000	965 000	16.0	750	900	6088	466	624	5	106
460	580	56	3	310 000	550 000	17.1	800	1 000	6892	473	567	2.5	34.3
	620	74	4	405 000	720 000	16.7	800	950	6992	476	604	3	62.6
	680	100	6	605 000	1 080 000	15.8	710	850	6092	486	654	5	123
480	600	56	3	315 000	575 000	17.2	800	950	6896	493	587	2.5	35.4
	650	78	5	450 000	815 000	16.6	750	900	6996	500	630	4	73.5
	700	100	6	605 000	1 090 000	15.9	710	850	6096	506	674	5	127
500	620	56	3	320 000	600 000	17.3	750	900	68/500	513	607	2.5	37.2
	670	78	5	460 000	865 000	16.7	710	850	69/500	520	650	4	82
	720	100	6	630 000	1 170 000	16.0	670	800	60/500	526	694	5	131
530	650	56	3	325 000	625 000	17.4	710	850	68/530	543	637	2.5	39.8
	710	82	5	455 000	870 000	16.8	670	800	69/530	550	690	4	89.8
	780	112	6	680 000	1 300 000	16.0	600	750	60/530	556	754	5	184
560	680	56	3	330 000	650 000	17.4	670	800	68/560	573	667	2.5	41.5
	750	85	5	525 000	1 040 000	16.7	600	750	69/560	580	730	4	105
	820	115	6	735 000	1 500 000	16.2	560	670	60/560	586	793.5	5	203
600	730	60	3	355 000	735 000	17.5	600	710	68/600	613	717	2.5	50.9
	800	90	5	550 000	1 160 000	16.9	560	670	69/600	620	780	4	120
	870	118	6	790 000	1 640 000	16.1	530	630	60/600	626	844	5	236

Note (1) When heavy axial loads are applied, d_a and D_a can be adjusted up to the shoulder diameter of the races. Please consult NSK for details.

■ SINGLE-ROW DEEP GROOVE BALL BEARINGS

Bore Diameter 630 – 800 mm

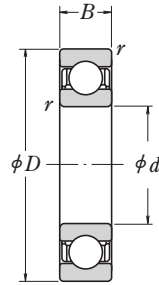

Open

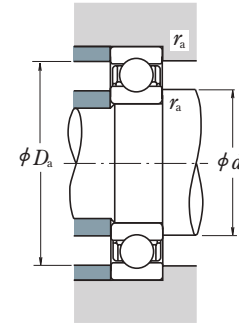

Dynamic Equivalent Load

$$P = XF_r + YF_a$$

$\frac{f_0 F_a}{C_{0r}}$	e	$\frac{F_a}{F_r} \leq e$		$\frac{F_a}{F_r} > e$	
		X	Y	X	Y
0.172	0.19	1	0	0.56	2.30
0.345	0.22	1	0	0.56	1.99
0.689	0.26	1	0	0.56	1.71
1.03	0.28	1	0	0.56	1.55
1.38	0.30	1	0	0.56	1.45
2.07	0.34	1	0	0.56	1.31
3.45	0.38	1	0	0.56	1.15
5.17	0.42	1	0	0.56	1.04
6.89	0.44	1	0	0.56	1.00

Static Equivalent Load

$$\frac{F_a}{F_r} > 0.8, P_0 = 0.6F_r + 0.5F_a$$

$$\frac{F_a}{F_r} \leq 0.8, P_0 = F_r$$

Boundary Dimensions (mm)				Basic Load Ratings (N)		Factor f_0	Limiting Speeds (min^{-1})		Bearing Designations Open	Abutment and Fillet Dimensions (mm)			Mass (kg) approx.
d	D	B	r min.	C_r	C_{0r}		Grease	Oil		$d_a^{(1)}$ min.	$D_a^{(1)}$ max.	r_a max.	
630	780	69	4	420 000	890 000	17.3	560	670	68/630 69/630 60/630	646	764	3	71.3
	850	100	6	625 000	1 350 000	16.7	530	630		656	824	5	163
	920	128	7.5	750 000	1 620 000	16.4	480	600		662	888	6	285
670	820	69	4	435 000	965 000	17.4	500	630	68/670 69/670 60/670	686	804	3	75.4
	900	103	6	675 000	1 460 000	16.7	480	560		696	874	5	181
	980	136	7.5	765 000	1 730 000	16.6	450	530		702	948	6	351
710	870	74	4	480 000	1 100 000	17.4	480	560	68/710 69/710	726	854	3	92.6
	950	106	6	715 000	1 640 000	16.8	450	530		736	924	5	208
750	920	78	5	525 000	1 260 000	17.4	430	530	68/750 69/750	770	900	4	110
	1 000	112	6	785 000	1 840 000	16.7	400	500		776	974	5	245
800	980	82	5	530 000	1 310 000	17.5	400	480	68/800 69/800	820	960	4	132
	1 060	115	6	825 000	2 050 000	16.8	380	450		826	1 034	5	275

Note (1) When heavy axial loads are applied, d_a and D_a can be adjusted up to the shoulder diameter of the races. Please consult NSK for details.

Bore Diameter 10 – 100 mm

Boundary Dimensions (mm)			Basic Load Ratings (N)		Recommended Fits (1)	Bearing Designations			
<i>d</i>	<i>D</i>	<i>B</i>	<i>C_r</i>	<i>C_{0r}</i>		Basic Designation (Open)	Shields	Contact Seal (2)	Non-Contact Seal
10	26	8	4 550	1 970	H7 or G6	6000	ZZ	DDU	VV
	30	9	5 100	2 390		6200	ZZ	DDU	VV
	35	11	8 100	3 450		6300	ZZ	DDU	VV
12	28	8	5 100	2 370		6001	ZZ	DDU	VV
	32	10	6 800	3 050		6201	ZZ	DDU	VV
	37	12	9 700	4 200		6301	ZZ	DDU	VV
15	32	9	5 600	2 830		6002	ZZ	DDU	VV
	35	11	7 650	3 750		6202	ZZ	DDU	VV
	42	13	11 400	5 450		6302	ZZ	DDU	VV
17	35	10	6 000	3 250		6003	ZZ	DDU	VV
	40	12	9 550	4 800		6203	ZZ	DDU	VV
	47	14	13 600	6 650		6303	ZZ	DDU	VV
20	42	12	9 400	5 000		6004	ZZ	DDU	VV
	47	14	12 800	6 600		6204	ZZ	DDU	VV
	52	15	15 900	7 900		6304	ZZ	DDU	VV
25	47	12	10 100	5 850		6005	ZZ	DDU	VV
	52	15	14 000	7 850		6205	ZZ	DDU	VV
	62	17	20 600	11 200		6305	ZZ	DDU	VV
30	55	13	13 200	8 300		6006	ZZ	DDU	VV
	62	16	19 500	11 300		6206	ZZ	DDU	VV
	72	19	26 700	15 000	6306	ZZ	DDU	VV	
35	62	14	16 000	10 300	6007	ZZ	DDU	VV	
	72	17	25 700	15 300	6207	ZZ	DDU	VV	
	80	21	33 500	19 200	6307	ZZ	DDU	VV	
40	68	15	16 800	11 500	6008	ZZ	DDU	VV	
	80	18	29 100	17 900	6208	ZZ	DDU	VV	
	90	23	40 500	24 000	6308	ZZ	DDU	VV	
45	75	16	20 900	15 200	6009	ZZ	DDU	VV	
	85	19	31 500	20 400	6209	ZZ	DDU	VV	
	100	25	53 000	32 000	6309	ZZ	DDU	VV	
50	80	16	21 800	16 600	6010	ZZ	DDU	VV	
	90	20	35 000	23 200	6210	ZZ	DDU	VV	
	110	27	62 000	38 500	6310	ZZ	DDU	VV	
55	90	18	28 300	21 200	6011	ZZ	DDU	VV	
	100	21	43 500	29 300	6211	ZZ	DDU	VV	
	120	29	71 500	44 500	6311	ZZ	DDU	VV	
60	95	18	29 500	23 200	6012	ZZ	DDU	VV	
	110	22	52 500	36 000	6212	ZZ	DDU	VV	
	130	31	82 000	52 000	6312	ZZ	DDU	VV	
65	100	18	30 500	25 200	6013	ZZ	DDU	VV	
	120	23	57 500	40 000	6213	ZZ	DDU	VV	
	140	33	92 500	60 000	6313	ZZ	DDU	VV	
70	110	20	38 000	31 000	6014	ZZ	DDU	VV	
	125	24	62 000	44 000	6214	ZZ	DDU	VV	
	150	35	104 000	68 000	6314	ZZ	DDU	VV	
75	115	20	39 500	33 500	6015	ZZ	DDU	VV	
	130	25	66 000	49 500	6215	ZZ	DDU	VV	
80	125	22	47 500	40 000	6016	ZZ	DDU	VV	
	140	26	72 500	53 000	6216	ZZ	DDU	VV	
85	130	22	49 500	43 000	6017	ZZ	DDU	VV	
	150	28	84 000	62 000	6217	ZZ	DDU	VV	
90	140	24	58 000	50 000	6018	ZZ	DDU	VV	
95	145	24	60 500	54 000	6019	ZZ	DDU	VV	
100	150	24	60 000	54 000	6020	ZZ	DDU	VV	

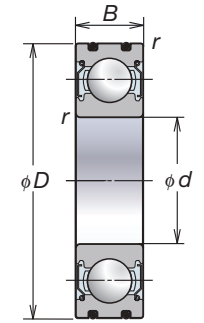

Notes (1) Although recommended fits are H7 or G6, G6 is recommended when used under conditions that prioritize insertion under light preload.

(2) Low-contact seals are available for sealed bearings; contact NSK for details.